

**End-Use Electrification in the Residential Sector: A General Equilibrium Analysis
of Technology Advancements**

by

Tanvir Singh Madan

B.S., Electrical and Computer Engineering
Worcester Polytechnic Institute, 2010

SUBMITTED TO THE ENGINEERING SYSTEMS DIVISION
IN PARTIAL FULFILLMENT OF THE REQUIREMENTS FOR THE DEGREE OF

MASTER OF SCIENCE IN TECHNOLOGY AND POLICY

AT THE

MASSACHUSETTS INSTITUTE OF TECHNOLOGY

JUNE 2012

© 2012 Massachusetts Institute of Technology. All rights reserved.

Signature of Author

Engineering Systems Division
May 11, 2012

Certified by

Dr. John M. Reilly
Senior Lecturer, Sloan School of Management
Thesis Supervisor

Accepted by

Joel P. Clark
Professor of Materials Systems and Engineering Systems
Acting Director, Technology & Policy Program

End-Use Electrification in the Residential Sector: A General Equilibrium Analysis of Technology Advancements

by

Tanvir Singh Madan

Submitted to the Engineering Systems Division on
May 11, 2012 in Partial Fulfillment of the Requirements for the
Degree of Master of Science in Technology and Policy

ABSTRACT

The residential sector in the U.S. is responsible for about 20% of the country's primary energy use (EIA, 2011). Studies estimate that efficiency improvements in this sector can reduce household energy consumption by over 25% by 2020 (McKinsey Global Energy and Materials, 2009). In this thesis, given the increasing amount of attention that both policy-makers and industry are giving to residential energy use, I examine the implications of end-use electrification and efficiency improvements in households. In particular, I focus on high efficiency electric technologies for heating and cooling (referred to as HVAC) needs. Advancements in technologies such as heat pumps are beginning to make the economic case for switching from end-uses of gas to end-uses of electricity in the residential sector. I examine the implications of such end-use electrification, ranging from its impact on energy consumption to its contribution to the abatement of greenhouse gas (GHG) emissions.

I use the MIT Emissions Prediction and Policy Analysis (EPPA) model, a computable general equilibrium model, to analyze the research question. The EPPA model captures full economy-wide impacts of policy mandates and technology changes. First, I added further detail to household energy consumption in the model. Then, I introduced technology changes corresponding to advanced electric technologies for residential heating and cooling and tested their impact with policies that either support or inhibit their entry into the marketplace.

I find two interesting results from the analysis. First, if policies are enacted to support advanced electric HVAC technologies, they displace end-uses of gas and increase household electricity consumption. Second, household end-use electrification in the U.S. leads to an increase in overall emissions in the economy, given that the overall emissions of any electric appliance depend not only on the end-use efficiency of the appliance but also on the efficiency of generating and distributing electricity. Thus, end use electrification only helps in emissions abatement if the power sector becomes less carbon intensive.

Thesis Supervisor: Dr. John M. Reilly

Title: Senior Lecturer, Sloan School of Management

ACKNOWLEDGEMENTS

None of this work would have been possible without the support of the Joint Program family. This has been a great place to work; the support of the professors and scientists, fellow researchers and administrative staff is something I am very thankful for. I would like to thank John Reilly, my research supervisor, for providing me the opportunity to work in this group and for guiding and shaping my research project. A very special thank you to Dr. Sergey Paltsev; his patience, guidance and support make the Joint Program a great place to work at. I would also like to thank Fannie Barnes and Tony Tran for the support they provide to the entire Joint Program family. A warm thank you to Henry Chen for being supportive and patient and helping me throughout the modeling process.

The last two years at MIT have been a truly worthwhile experience. I would like to thank all those that have made my time at MIT exciting and engaging. A special thank you to the Technology and Policy Program family, everyone from my fellow students to the faculty and administrative staff. This experience could never have been the same without your presence. I would also like to acknowledge the groups and organizations at MIT that I have worked with over the last 2 years. In particular, I would like to thank the MIT Energy Conference family for providing me an experience that will last a lifetime.

Last, but by no means least, I would like to thank my family and friends. Thank you for all your support and for all the great times we have shared over the past two years. I dedicate my degree to my family – the unwavering pillar of my life.

Table of Contents

- List of Figures 7
- List of Tables 9
- 1. Introduction 10
- 2. Background & Motivation 12
 - 2.1 U.S. Energy Use and Energy Efficiency 12
 - 2.1.1 Energy Consumption: Sector Statistics 12
 - 2.1.2 Energy Efficiency and Savings Potential 14
 - 2.2 Research Questions..... 16
 - 2.3 Residential End-Use Electrification & Efficiency Improvement Opportunities 17
 - 2.3.1 Household Energy Consumption Characteristics..... 17
 - 2.3.2 Household Energy Policies and Efficiency Related Savings..... 19
- 3. Methodology 24
 - 3.1 Background of the EPPA Model 24
 - 3.2 Functionality of the EPPA Model..... 26
 - 3.2.1 Equilibrium Structure 26
 - 3.2.2 Production Structure 27
 - 3.2.3 Consumption Structure 27
 - 3.2.4 Policy Constraints..... 28
 - 3.3 Household Consumption Modeling..... 29
 - 3.3.1 Application Based Consumption Blocks 30
 - 3.3.2 Modeling New HVAC Technologies 33
 - 3.3.3 Policy Implementation 36
- 4. Results..... 38
 - 4.1 Enhanced Base Model 38
 - 4.2 Policy Cases Analysis 41
 - 4.2.1 Household Indicators 41
 - 4.2.2 Economy-Wide Indicators 44
 - 4.3 Parameter Sensitivity 47

4.4	Comparison to Other Studies	53
5.	Future Work & Conclusions	56
	Bibliography.....	59

List of Figures

FIGURE 1- THESIS STRUCTURE	11
FIGURE 2 – ESTIMATED U.S. ENERGY PRODUCTION AND END-USE, 2009 (LAWRENCE LIVERMORE NATIONAL LABORATORY, 2011)	12
FIGURE 3 - U.S. TOTAL ENERGY CONSUMPTION ESTIMATES BY END-USE SECTOR, 1949-2010 (EIA, 2011)	13
FIGURE 4 - U.S. PRIMARY ENERGY PRODUCTION BY MAJOR SOURCE, 1949-2010 (EIA, 2011)	13
FIGURE 5 - ENERGY EFFICIENCY POTENTIAL IN THE U.S. ECONOMY (MCKINSEY GLOBAL ENERGY AND MATERIALS, 2009)	14
FIGURE 6 - AVERAGE ACHIEVABLE ELECTRIC EFFICIENCY POTENTIAL PER YEAR, BY SECTOR AND LEVEL OF INCENTIVE (CHANDLER, 2010).....	15
FIGURE 7 – IPCC GHG EMISSIONS ABATEMENT ESTIMATES (INTERGOVERNMENTAL PANEL ON CLIMATE CHANGE, 2007)	15
FIGURE 8 – U.S. HOUSEHOLD ENERGY CONSUMPTION BY END-USE 1990-2005 (EIA, 2012).....	17
FIGURE 9 – U.S. HOUSEHOLD ENERGY CONSUMPTION BY ENERGY SOURCE 1990-2005 (EIA, 2012)	18
FIGURE 10 –ENERGY EFFICIENCY RESOURCE STANDARDS (EERS) GEOGRAPHICAL DISTRIBUTION - OCTOBER 2011 (AMERICAN COUNCIL FOR AN ENERGY-EFFICIENT ECONOMY, 2011)	20
FIGURE 11 - NET ECONOMIC SAVINGS FROM EXISTING STANDARDS (AMERICAN COUNCIL FOR AN ENERGY-EFFICIENT ECONOMY, 2012)	21
FIGURE 12 - MIT EMISSIONS PREDICTION AND POLICY ANALYSIS (EPPA) MODEL (PALTSEV ET AL., 2005)	25
FIGURE 13- REFINED OIL PRODUCTION STRUCTURE IN THE EPPA MODEL (PALTSEV ET AL., 2005).....	27
FIGURE 14 - CONSUMPTION STRUCTURE IN THE EPPA MODEL (PALTSEV ET AL., 2005)	28
FIGURE 15- NEW HEATING AND COOLING CONSUMPTION BLOCK.....	31
FIGURE 16 - CONSUMPTION BLOCK FOR NON-HVAC HOUSEHOLD CONSUMPTION	33
FIGURE 17 – TYPICAL BACKSTOP TECHNOLOGY PRODUCTION BLOCK IN THE EPPA MODEL	35
FIGURE 18 - DESCRIPTION OF THE EPPA MODEL CHANGES.....	38
FIGURE 19 - U.S. HOUSEHOLD ELECTRIC CONSUMPTION (ORIGINAL VS. ENHANCED MODEL)	39
FIGURE 20 - U.S. TOTAL ELECTRICITY CONSUMPTION (ORIGINAL VS. ENHANCED MODEL).....	39
FIGURE 21 - MODEL RESULTS - U.S. HOUSEHOLD ELECTRICITY CONSUMPTION	41
FIGURE 22 - MODEL RESULTS - U.S. HOUSEHOLD ELECTRICITY CONSUMPTION	42
FIGURE 23 - MODEL RESULTS - U.S. HOUSEHOLD GAS CONSUMPTION	43
FIGURE 24 - MODEL RESULTS - U.S. HOUSEHOLD GAS CONSUMPTION	43
FIGURE 25- MODEL RESULTS - U.S. ELECTRICITY CONSUMPTION	45
FIGURE 26 - MODEL RESULTS - U.S. ELECTRICITY CONSUMPTION	45
FIGURE 27 - MODEL RESULTS - U.S. TOTAL GHG EMISSIONS.....	46

FIGURE 28 - SENSITIVITY ANALYSIS - $\sigma_{e_{hc}_S}$ - U.S. RESIDENTIAL ELECTRICITY CONSUMPTION.....	47
FIGURE 29 - SENSITIVITY ANALYSIS - $\sigma_{e_{hc}_S}$ - U.S. RESIDENTIAL GAS CONSUMPTION	48
FIGURE 30 - SENSITIVITY ANALYSIS - $\sigma_{e_{hc}_S}$ - U.S. TOTAL ELECTRICITY CONSUMPTION	48
FIGURE 31 - SENSITIVITY ANALYSIS - $\sigma_{e_{hc}_S}$ - U.S. TOTAL GHG EMISSIONS	49
FIGURE 32 - SENSITIVITY ANALYSIS - $\sigma_{e_{ne_nhc}}$ - U.S. RESIDENTIAL ELECTRICITY CONSUMPTION.....	50
FIGURE 33 -SENSITIVITY ANALYSIS - $\sigma_{e_{ne_nhc}}$ - U.S. RESIDENTIAL GAS CONSUMPTION	50
FIGURE 34 - SENSITIVITY ANALYSIS - $\sigma_{e_{ne_nhc}}$ - U.S. TOTAL ELECTRICITY CONSUMPTION.....	51
FIGURE 35 - SENSITIVITY ANALYSIS –INPUT SHARES- U.S. RESIDENTIAL ELECTRICITY CONSUMPTION	52
FIGURE 36 - SENSITIVITY ANALYSIS –INPUT SHARES- U.S. RESIDENTIAL GAS CONSUMPTION.....	52
FIGURE 37 - EFFICIENCY RELATED ELECTRICITY SAVINGS POTENTIAL (CHANDLER, 2010)	53
FIGURE 38 - MODEL RESULTS - U.S. ELECTRICITY CONSUMPTION	54
FIGURE 39 - POTENTIAL OF EMISSIONS ABATEMENT FROM THE BUILDINGS SECTOR (MCKINSEY GLOBAL ENERGY AND MATERIALS, 2009).....	55

List of Tables

TABLE 1 - SPACE HEATING IN THE U.S. BY ENERGY SOURCE (EIA, 2012)	18
TABLE 2 - WATER HEATING IN THE U.S. BY ENERGY SOURCE (EIA, 2012).....	19
TABLE 3 - INCREMENTAL ELECTRICITY SAVINGS BY TOP 10 U.S. STATES IN 2009 (AMERICAN COUNCIL FOR AN ENERGY-EFFICIENT ECONOMY, 2011).....	20
TABLE 4- POTENTIAL ENERGY SAVINGS FROM NEW STANDARDS (AMERICAN COUNCIL FOR AN ENERGY-EFFICIENT ECONOMY, 2012)	22
TABLE 5 - POTENTIAL ECONOMIC SAVINGS FROM FUTURE STANDARDS (AMERICAN COUNCIL FOR AN ENERGY-EFFICIENT ECONOMY, 2012)	23
TABLE 6- THE EPPA MODEL: REGIONS AND SECTORS.....	25
TABLE 7 - END-USE ENERGY CONSUMPTION IN THE U.S. RESIDENTIAL SECTOR	30
TABLE 8 - SPACE HEATING AND WATER HEATING CONSUMPTION IN THE U.S. BY ENERGY SOURCE (EIA, 2012)	32
TABLE 9 - MARK-UP AND FIXED FACTORS FOR NEW HEATING AND COOLING TECHNOLOGIES	34
TABLE 10 - MODEL RESULTS – CHANGE IN U.S. HOUSEHOLD EMISSIONS (%).....	44
TABLE 11 - MODEL RESULTS – REDUCTION IN U.S. HOUSEHOLD EMISSIONS (%).....	55

1. Introduction

In today's discussions around energy and climate, one often hears about measures (whether technology or policy driven) that aim to reduce greenhouse gas (GHG) emissions and increase energy security and independence. Although there are aspects of the energy and climate debate that are politically and internationally sensitive, energy efficiency seems to be a favored and less-contested concept or pathway in addressing a variety of energy and climate goals. Energy efficiency can mean a variety of things; ranging from improving the efficiency of thermo-electric processes in fossil fuel plants to improving the end-use efficiency of applications used in households.

Although energy efficiency can take on numerous forms, I primarily focus on opportunities provided by advanced electric heating and cooling equipment i.e. the electrification of and improvements in end-use efficiency of HVAC equipment in households. I make use of a computable general equilibrium (CGE) model to analyze the impact of the same on energy consumption and examine its ability to contribute to the abatement of GHG emissions. CGE models, including the MIT Emission Prediction and Policy Analysis (EPPA) mode (which I use to model the above question), typically have low levels of detail on demand side technologies and have traditionally been used to analyze supply side technologies and policies. Within the EPPA modeling group, this thesis serves as one of the first attempts to model demand-side technology changes.

This thesis is organized into five chapters as shown below in Figure 1. Chapter 1 introduces the research question and explains the structure of the thesis.

Chapter 2 discusses the importance of energy efficiency, highlighting some studies in the area, and also provides detail on options in the residential sector that are well positioned to make advancements through end-use electrification.

Chapter 3 describes the method used to implement this research – the EPPA Model. The chapter provides some background information on the model and its applications and functionality. I identify the changes that are made to the model to make use of bottom-up engineering data on technology options in the residential sector.

Chapter 4 highlights results of the simulations conducted with the enhanced model. The chapter describes the impact of residential end-use electrification & efficiency improvements on the energy sector – both in terms of energy and electricity use and GHG emissions abatement.

Chapter 5 offer conclusions and provides policy recommendations along with highlighting avenues for further investigation.

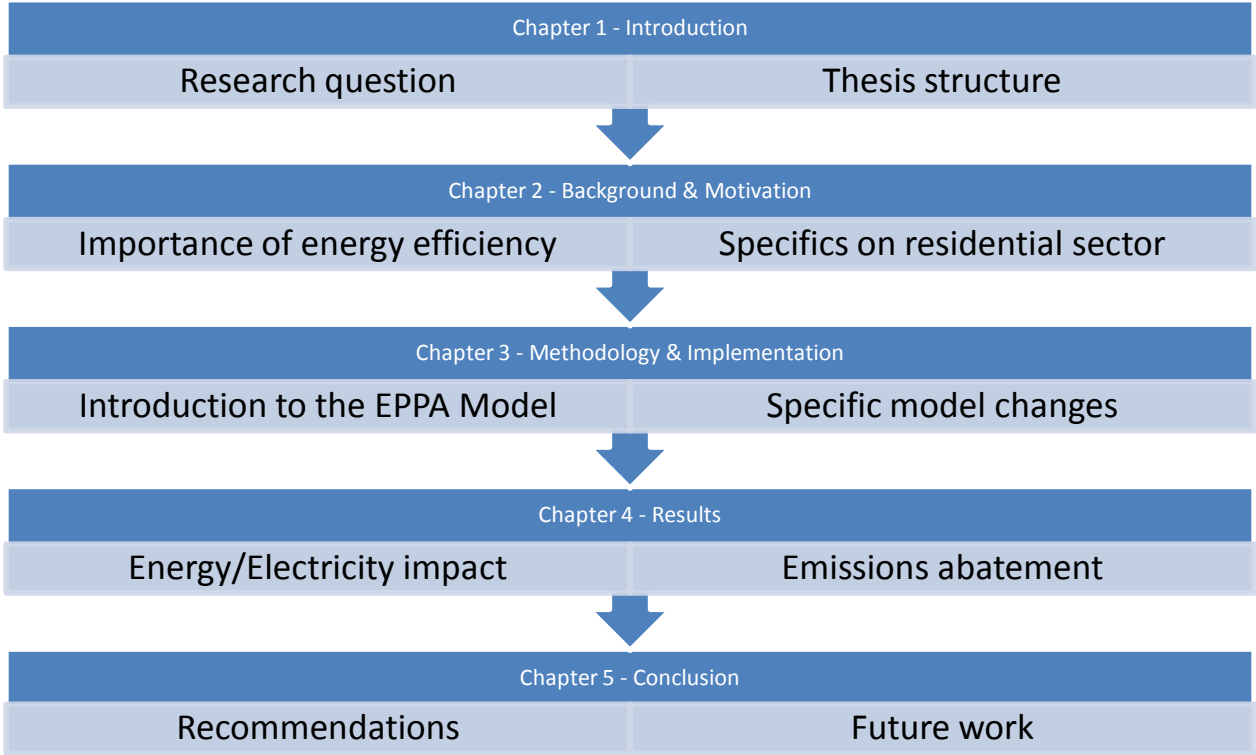

Figure 1- Thesis structure

2. Background & Motivation

In this chapter, I review the potential impact that end-use electrification and energy efficiency in the residential sector can have on energy consumption and emissions abatement. I then explain the specific research question and provide some analysis and data to highlight its importance.

2.1 U.S. Energy Use and Energy Efficiency

2.1.1 Energy Consumption: Sector Statistics

As of 2010, the residential sector in the United States was responsible for about 20% of the country's primary energy use (EIA, 2011). In terms of end use energy, as shown in the figure below, the residential and commercial sectors in the U.S. were responsible for about 30% of end use energy consumption in 2009.

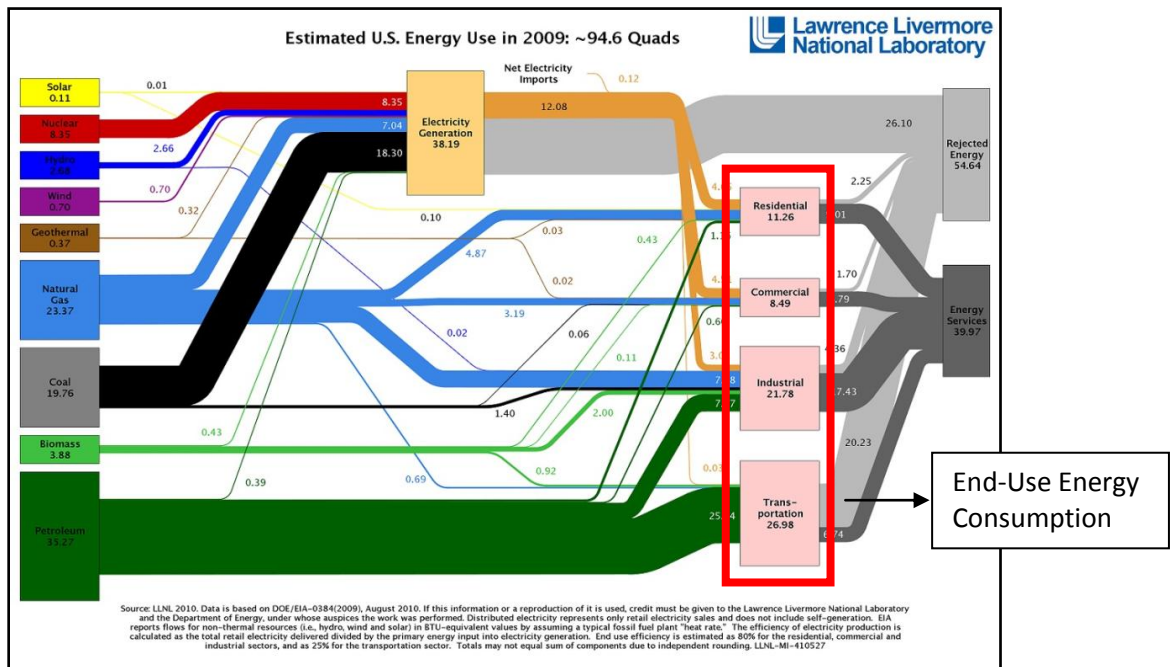

Figure 2 – Estimated U.S. Energy Production and End-Use, 2009 (Lawrence Livermore National Laboratory, 2011)

As shown in the figure below, it is important to note that the share of these two sectors in end-use energy consumption has been increasing over the years whereas the share of the industrial sector has been growing at a much slower rate (even decreasing for certain periods) in recent times. With a variety

of energy-efficient technologies entering the residential and commercial sectors, these sectors provide great opportunity for the reduction of energy consumption.

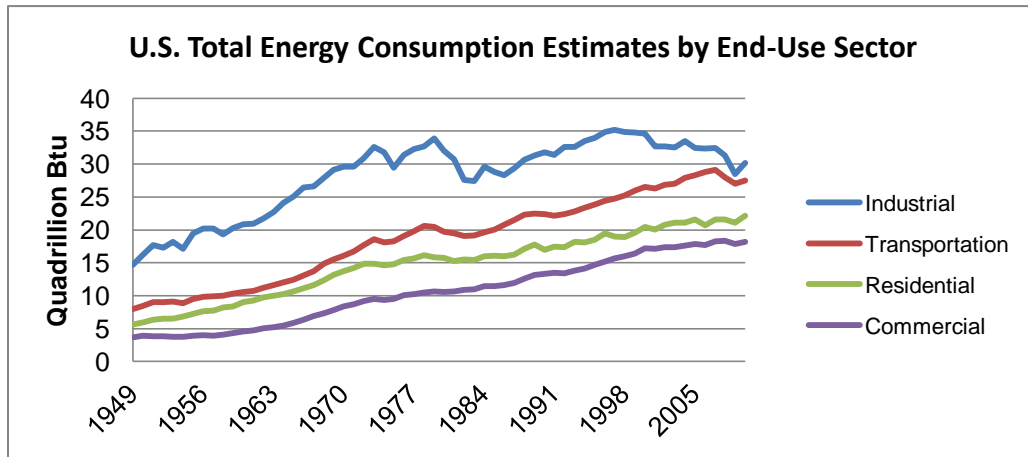

Figure 3 - U.S. Total Energy Consumption Estimates by End-Use Sector, 1949-2010 (EIA, 2011)

Although the residential and commercial sectors are responsible for a considerable amount of energy consumption, it is important to acknowledge where these sectors get their energy from (see figure below). If energy policy is enacted that pushes for increased electrification and increased energy efficiency in the end-use sectors, it is important to keep in mind that doing so may or may not lead to a decrease in emissions since it will depend on the fuel mix of the power sector.

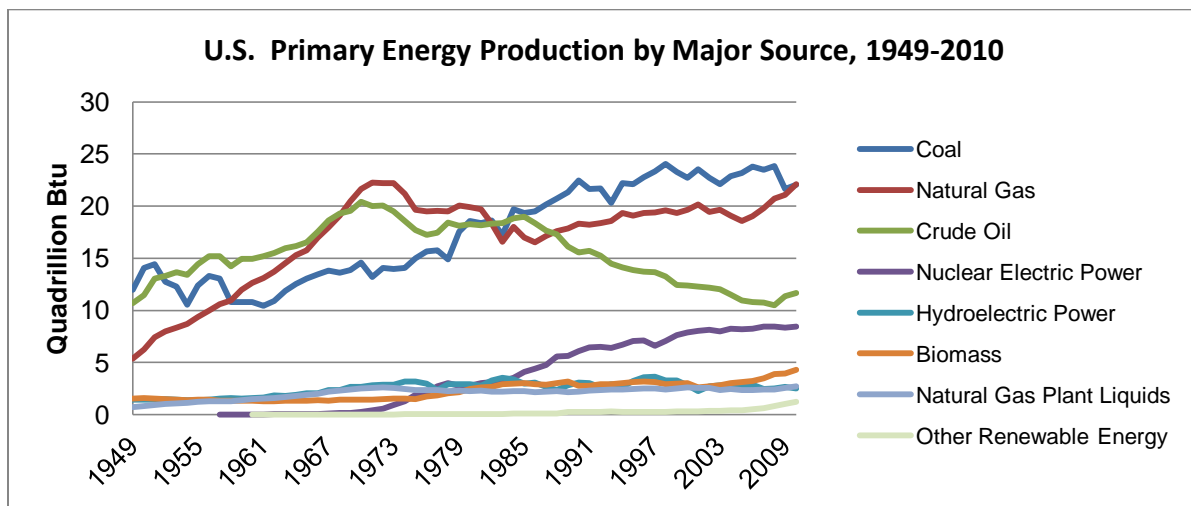

Figure 4 - U.S. Primary Energy Production by Major Source, 1949-2010 (EIA, 2011)

Recent changes in the natural gas industry, particularly the growth of hydraulic fracturing, have led experts to believe that natural gas could play a growing and vital role in America’s energy future (Moniz et al., 2011). This makes it even more critical to draft energy efficiency policies that complement the energy mix and appreciate that energy efficiency improvements are most effective in reducing emissions if they are accompanied by a grid moving towards de-carbonization.

2.1.2 Energy Efficiency and Savings Potential

In a 2009 study carried out by McKinsey Global Energy and Materials, it was estimated that between 2008 and 2020, the residential and commercial sectors within the U.S. could achieved end-use consumption savings of 29% and 28% respectively (McKinsey Global Energy and Materials, 2009).

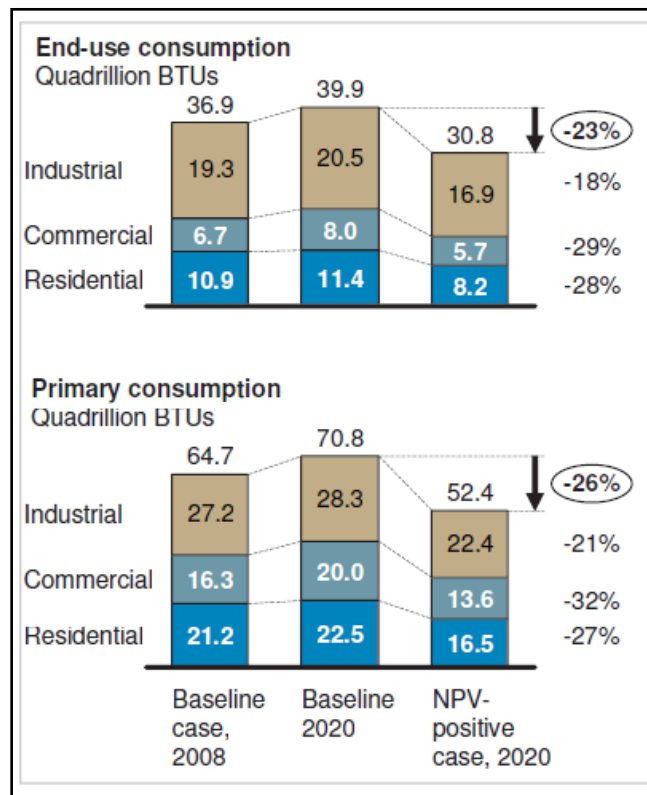

Figure 5 - Energy Efficiency Potential in the U.S. economy (McKinsey Global Energy and Materials, 2009)

In a recent paper that looked at 20 studies of electric efficiency potential and categorized them into one review (Chandler, 2010); it was found that the residential sector could promote electricity savings anywhere from 0.1% to 1.3% per year, depending on the type of incentives provide. In the graph below, the different shades of the bars represent different percentages of incentives (incentive here refers to the covering of incremental costs). For example, the 100% bars represent the case where 100% of

incremental costs of switching to a more efficient electric technology are covered by state or federal policies.

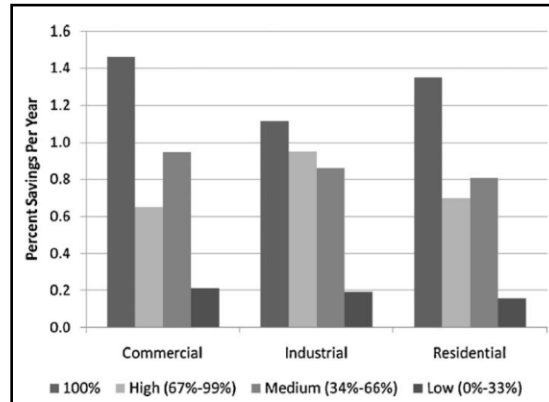

Figure 6 - Average Achievable Electric Efficiency Potential per Year, by Sector and Level of Incentive (Chandler, 2010)

The McKinsey report number seems to match those presented in the paper cited above in the case where incentives provided are on the higher side. However, as mentioned earlier, these efficiency improvements need to be thought of in conjunction with emissions abatement.

In a report published in 2007, the Intergovernmental Panel on Climate Change (Intergovernmental Panel on Climate Change, 2007) found that for different levels of a carbon tax (<20, <50 and <100 dollars per metric ton of carbon dioxide equivalent), the buildings sector had the highest potential for emissions reductions (shown in the figure below). These studies reiterate the point that household provide vast opportunities for both technology and policy changes that enable the proliferation of high-efficiency devices and hence are positioned to impact energy consumption and GHG emissions.

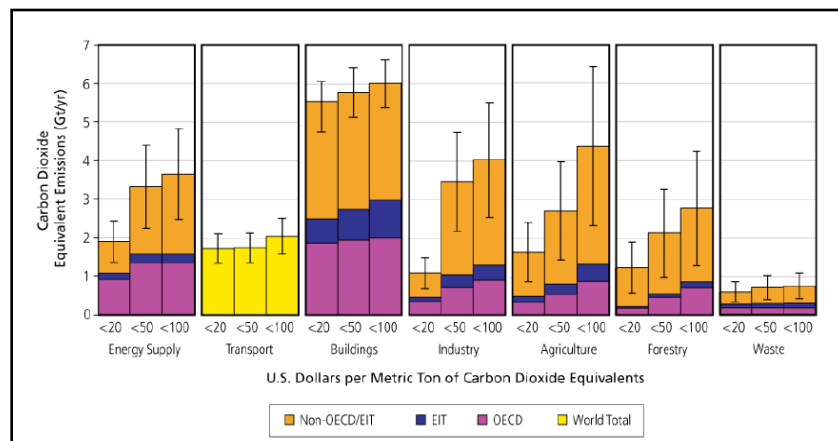

Figure 7 – IPCC GHG Emissions Abatement Estimates (Intergovernmental Panel on Climate Change, 2007)

2.2 Research Questions

Although there are a variety of technology choices that impact residential energy use, in this thesis I focus on residential heating and cooling technologies (HVAC). The research question is as follows: What are the household and economy-wide impacts of advancements in electric HVAC technologies in the residential sector? There are a few reasons why the thesis focuses on these technologies in particular, the reasons being listed below:

- **Technology Changes** – There have been vast technology advancements in electric heating and cooling applications that make them appropriate for this study. New electric technologies are characterized by significant advancements in end-use efficiency and studies indicate that they will play a major role in reducing energy consumption and lead to significant emissions reduction.
- **Fuel-switching** – For residential heating purposes, there exist opportunities to switch from end-use gas consumption to electricity, given the increasing efficiency of electric heating appliances. This thesis tackles the question of what it means for the energy sector if end-use electrification characterizes the future of heating in the residential sector.
- **Policy Changes**- There have been a large number of policy changes in the recent years that specifically deal with heating and cooling technologies, making this a timely issue to analyze.
- **Expenditure and Emissions** – Given that heating is responsible for the majority of housing energy consumption and expenditure¹, it is an area that policy-makers, technology players and consumers all are vested in.

The following section highlights some of the specific technology and policy areas that motivate the above research question.

¹ In 2005, U.S. households on average spent about \$57 billion on space heating, more than 25% of the total money spend on energy end-uses (EIA, 2005)

2.3 Residential End-Use Electrification & Efficiency Improvement Opportunities

2.3.1 Household Energy Consumption Characteristics

In order to capture the technology and policy changes taking place in residential HVAC equipment, one might begin by understanding the underlying consumption characteristics of U.S. households.

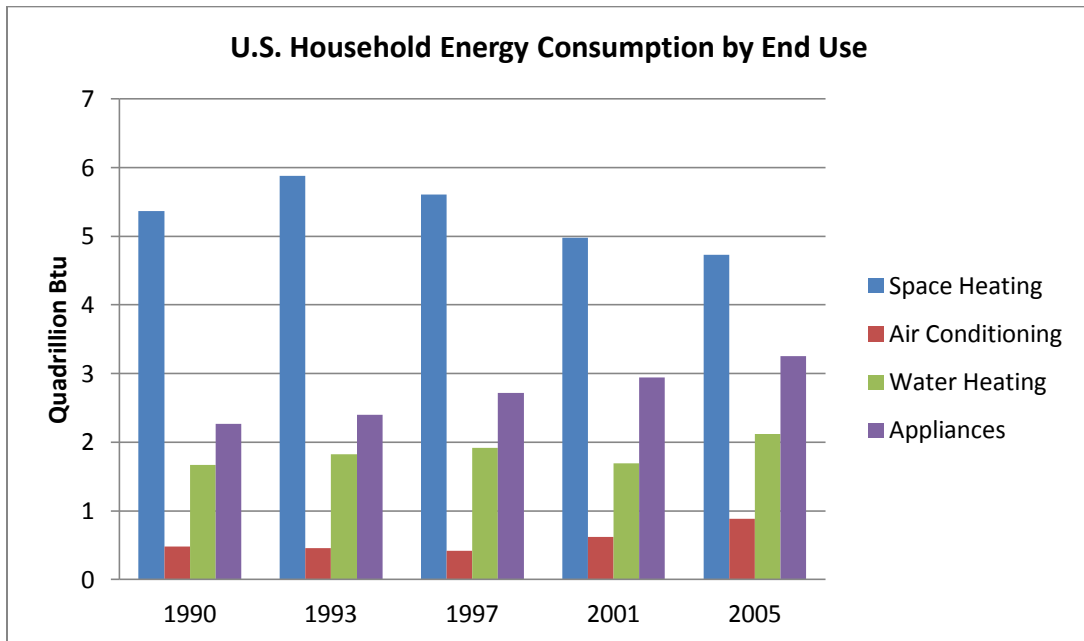

Figure 8 – U.S. Household Energy Consumption by End-Use 1990-2005 (EIA, 2012)

As the graph above indicates, space heating is responsible for the majority of U.S. household end-use energy consumption. However, there is a clear trend that the total consumption for space heating is decreasing whereas that for appliances is clearly increasing. This is due to a combination of the growing number of housing electric appliances as well as higher efficiency space heating equipment.

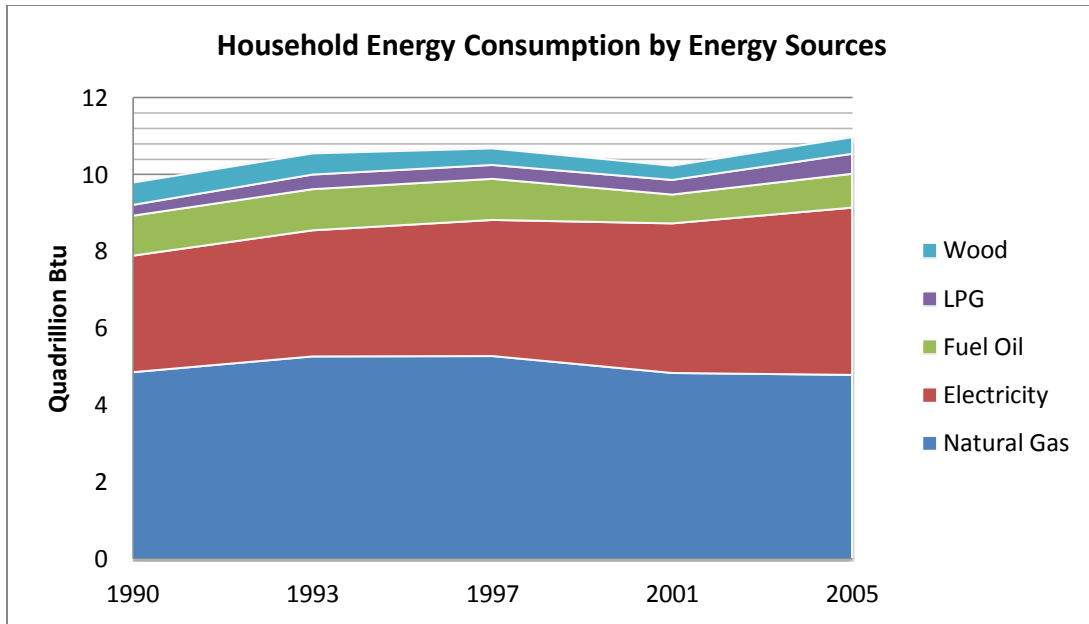

Figure 9 – U.S. Household Energy Consumption by Energy Source 1990-2005 (EIA, 2012)

In terms of the overall energy mix for the residential sector in the U.S., there has been an increase in electricity use over the years – driven by the lower costs and increased use of electric equipment, whether for heating purposes or appliances such as computer, TV’s ,etc.

Given that heating is responsible for the majority of consumption and that multiple sources of energy can be used for heating purposes, it is worth examining the shift in heating consumption patterns over the years, as shown below.

Table 1 - Space Heating in the U.S. by Energy Source (EIA, 2012)

Space Heating by Source	1997	2009
Natural Gas	52%	50%
Electricity	29%	35%
Liquefied Petroleum Gases	5%	5%
Distillate Fuel Oil	9%	6%
Wood	2%	2%
Other or No Equipment	2%	1%

Table 2 - Water Heating in the U.S. by Energy Source (EIA, 2012)

Water Heating	1997	2009
Natural Gas	52%	51%
Electricity	39%	41%
Liquefied Petroleum Gases	3%	4%
Distillate Fuel Oil	5%	3%
Other or No Water Heating	1%	1%

As the tables indicate, the share of gas in water and space heating has decreased slightly whereas the role of electricity has been increasing over time.

2.3.2 Household Energy Policies and Efficiency Related Savings

Broadly speaking, policies to improve energy efficiency can have a variety of implications – from reducing the imports of oil and promoting energy independence to reducing energy consumption and greenhouse gas emissions. The impacts of energy efficiency policies are often across many sectors; however, in the section below, I focus on those that primarily impact the residential sector. In general, there is a mix of federal and national policies that promote energy efficiency in the residential sector. In addition, agencies like the U.S. Department of Energy (DoE) and the Environmental Protection Agency (EPA) play a role in carrying out certain energy efficiency programs - including the popular labeling program, Energy Star.

- **Energy Efficiency Resource Standards (EERS)** – these are policies that set an annual energy efficiency target. They are used to enforce a percentage reduction in energy use from energy efficiency improvements. Although a federal EERS policy was not passed at the national level², more than 20 states have passed state-level EERS policies. The strongest EERS requirements exist in Vermont and Massachusetts, requiring about 2.5% savings in energy consumption annually. Some states have even combined an EERS with a Renewable Energy Standard (RES) policy. The figure below shows the geographical distribution of EERS policies in the U.S.

² For more information, see the American Clean Energy Security Act of 2009 at <http://www.aceee.org/topics/aces>

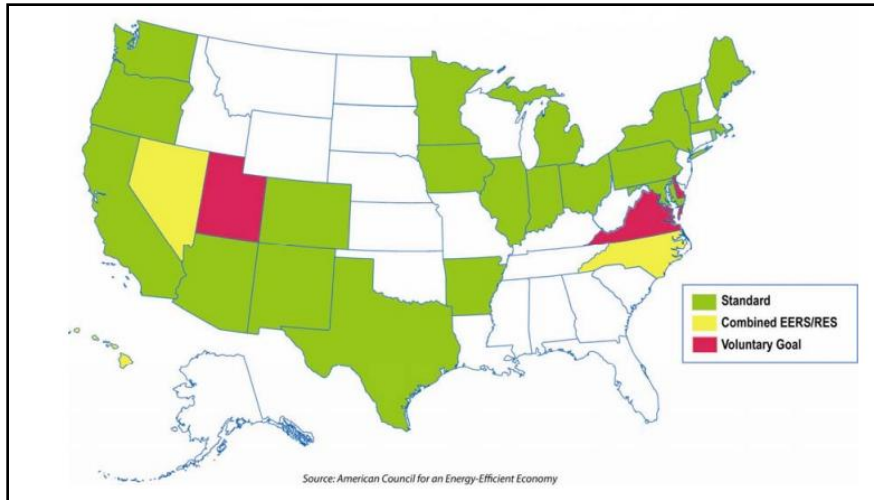

Figure 10 –Energy Efficiency Resource Standards (EERS) Geographical Distribution - October 2011 (American Council for an Energy-Efficient Economy, 2011)

The table below shows the top 10 states based on electricity savings in 2009 and expresses their savings as a percentage of total electricity sales.

Table 3 - Incremental Electricity Savings by Top 10 U.S. States in 2009 (American Council for an Energy-Efficient Economy, 2011)

State	2009 Total Incremental Electricity Savings (MWh)	Savings as Percent of Electricity Sales
Vermont	90,235.00	1.64%
Nevada	438,622.00	1.28%
Hawaii	113,159.00	1.12%
Rhode Island	81,543.00	1.07%
Minnesota	637,845.00	1.00%
Iowa	409,735.00	0.94%
California	2,293,007.00	0.88%
Wisconsin	583,506.00	0.88%
Massachusetts	458,658.00	0.84%
Connecticut	250,373.00	0.84%

- Codes, Standards and Retrofits** – The importance of codes in addressing some of the failures associated with promoting energy efficiency are well recognized (for case studies, see (International Energy Agency, 2008)) and hence a large amount of policy activity has been seen in this space. Minimum efficiency standards for residential appliances have been used for a few years now and have been recognized as one of the most successful and economical measures in promoting energy efficiency. Lastly, given the demography of America’s existing housing stock, there exist large potentials for energy savings through retrofit programs. Innovative financing solutions have played an important role in moving this space forward and a lot of opportunity still exists is maximizing the benefit seen through retrofit measures.

In a study carried out by ACEE (American Council for an Energy-Efficient Economy, 2012), energy savings for consumers from existing efficiency standards were evaluated and it was found that current standards would lead to economic savings of about \$65 billion by 2035 and the reduction of emissions equivalent to 5900 coal plants (approx. 475 MMT CO₂ by 2035).

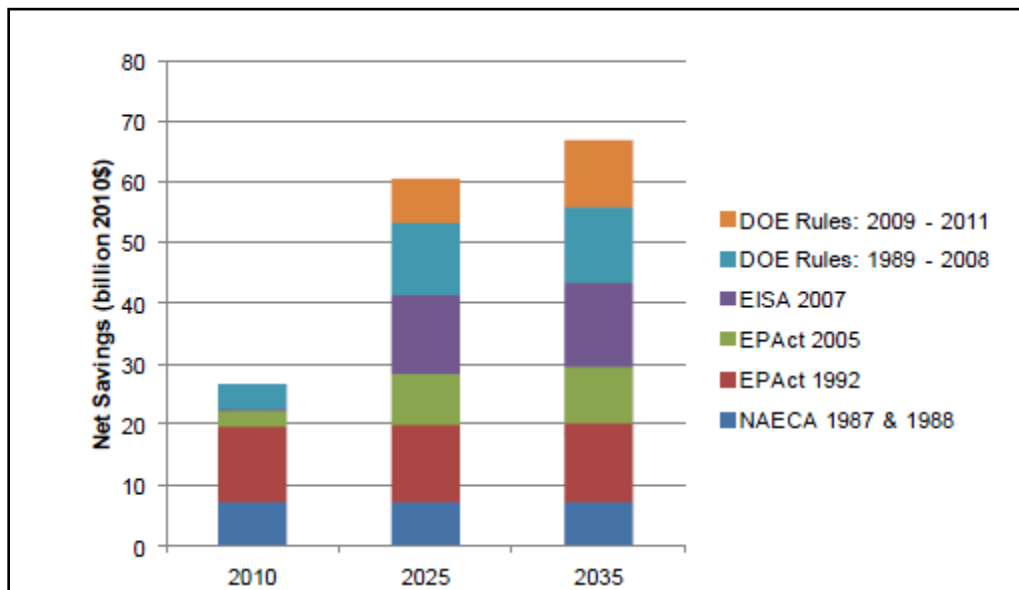

Figure 11 - Net Economic Savings from Existing Standards (American Council for an Energy-Efficient Economy, 2012)

ACEE also recently evaluated several technologies that offer potential energy savings and analyzed the specific technology changes that characterize these savings (American Council for an Energy-Efficient Economy, 2012). As it can be seen in the table below, they estimate that residential electric water

heaters and residential air handlers can lead to savings of about 4.1 and 2.9 quads by 2035, two of the three highest numbers reported in the ACEEE study.

Table 4- Potential Energy Savings from New Standards (American Council for an Energy-Efficient Economy, 2012)

Product	Annual Savings in 2025				Annual Savings in 2035				Cumulative Quads	
	Electricity (TWh)	Peak demand (GW)	Natural gas (Tbtu)	Water (billion gallons)	Electricity (TWh)	Peak demand (GW)	Natural gas (Tbtu)	Water (billion gallons)		
Residential:										
Air handlers	13.7	5.6	-	-	29.1	11.9	-	-	2.9	
Battery chargers	6.3	0.9	-	-	6.3	0.9	-	-	1.3	
Boilers (nat. gas)	-	-	14.1	-	-	-	39.8	-	0.3	
Clothes washers	5.3	0.8	25.3	160.3	7.0	1.0	33.8	213.7	1.5	
Computer equipment and components	11.8	1.6	-	-	11.8	1.6	-	-	1.7	
Dishwashers	2.6	0.8	3.2	15.8	2.6	0.8	3.2	15.8	0.5	
External power supplies	5.0	0.7	-	-	5.0	0.7	-	-	1.0	
Faucets (residential lavatory)	1.3	0.2	8.9	23.6	2.7	0.4	18.2	48.4	0.5	
Game consoles	7.9	1.1	-	-	7.9	1.1	-	-	1.1	
Microwave ovens	2.3	0.3	-	-	2.3	0.3	-	-	0.4	
Set-top boxes & digital communication equipment	14.7	2.0	-	-	14.7	2.0	-	-	2.3	
Televisions	9.4	0.2	-	-	9.9	0.2	-	-	1.5	
Toilets	-	-	-	44.6	-	-	-	91.5	-	
Water heaters	18.2	2.5	-	-	43.0	5.9	-	-	4.1	
<i>Residential total</i>	<i>98.5</i>	<i>16.8</i>	<i>51.6</i>	<i>244.3</i>	<i>142.3</i>	<i>27.0</i>	<i>95.0</i>	<i>369.5</i>	<i>19.0</i>	
Commercial/Industrial:										
Air conditioners, air-cooled	5.5	5.5	-	-	9.7	9.6	-	-	1.1	
Automatic ice makers	3.1	0.7	-	5.3	3.1	0.7	-	5.3	0.5	
Clothes washers	0.2	0.1	2.4	15.6	0.2	0.1	3.4	22.2	0.1	
Distribution transformers	10.9	1.5	-	-	22.4	3.1	-	-	2.3	
Electric motors	9.0	1.4	-	-	18.6	2.9	-	-	1.9	
Fans, blowers & ventilation equipment	3.1	0.5	-	-	8.5	1.4	-	-	0.7	
Furnaces, commercial warm-air	-	-	4.2	-	-	-	7.7	-	0.1	
Pre-rinse spray valve	0.8	0.1	9.5	14.9	0.8	0.1	9.5	14.9	0.3	
Pumps	8.8	1.4	-	-	13.9	2.2	-	-	1.7	
Refrigeration equipment	6.3	0.9	-	-	6.6	0.9	-	-	1.0	
Walk-in coolers and freezers	14.7	3.4	-	-	14.7	3.4	-	-	2.4	
Unit heaters	-	-	58.1	-	-	-	119.3	-	1.2	
Urinals	-	-	-	6.6	-	-	-	13.6	-	
<i>Commercial total</i>	<i>62.4</i>	<i>15.5</i>	<i>74.2</i>	<i>42.4</i>	<i>98.5</i>	<i>24.5</i>	<i>139.9</i>	<i>55.9</i>	<i>13.4</i>	
Lighting:										
Candelabra & intermediate base incandescent lamps	8.0	0.2	-	-	8.0	5.7	-	-	1.3	
General service fluorescent lamps	6.9	1.7	-	-	6.9	1.7	-	-	1.1	
HID lamps	2.9	1.0	-	-	-	-	-	-	0.4	
Incandescent reflector lamps	20.2	5.0	-	-	20.2	5.0	-	-	3.9	
Luminaires (portable light fixtures)	0.2	0.0	-	-	-	-	-	-	0.0	
Metal halide lamp fixtures	2.2	0.7	-	-	4.3	1.4	-	-	0.5	
Outdoor lighting fixtures	10.3	0.7	-	-	26.1	1.8	-	-	2.3	
<i>Lighting total</i>	<i>50.8</i>	<i>9.3</i>	<i>-</i>	<i>-</i>	<i>65.6</i>	<i>15.6</i>	<i>-</i>	<i>-</i>	<i>9.5</i>	
TOTAL:	212	42	126	287	306	67	235	425	41.9	

Focusing on the residential sector only, shown below are the economic savings possible from future standards in the residential sectors, taken from the same study cited above. Savings from air handlers and water heaters account for net present value of \$13,992 million and \$4,921 million in 2010 dollars respectively.

Table 5 - Potential Economic Savings from Future Standards (American Council for an Energy-Efficient Economy, 2012)

Product	Annual bill savings (million 2010\$)		Purchases through 2035		
	in 2025	in 2035	Present value of costs (million 2010\$)	Present value of savings (million 2010\$)	Net present value (million 2010\$)
Residential:					
Air handlers	\$1,573	\$3,331	\$4,748	\$18,740	\$13,992
Battery chargers	\$721	\$721	\$6,091	\$7,061	\$969
Boilers (nat. gas)	\$158	\$446	\$1,245	\$2,679	\$1,434
Clothes washers	\$2,010	\$2,680	\$3,355	\$19,246	\$15,891
Computer equipment and components	\$1,348	\$1,348	\$0	\$8,608	\$8,608
Dishwashers	\$445	\$445	\$1,076	\$3,852	\$2,777
External power supplies	\$575	\$575	\$3,253	\$5,558	\$2,305
Faucets (residential lavatory)	\$413	\$847	\$332	\$5,692	\$5,360
Game consoles	\$910	\$910	\$0	\$5,263	\$5,263
Microwave ovens	\$267	\$267	\$392	\$2,145	\$1,753
Set-top boxes & digital communication equipment	\$1,679	\$1,679	\$0	\$11,586	\$11,586
Televisions	\$1,082	\$1,139	\$0	\$8,260	\$8,260
Toilets	\$312	\$640	\$0	\$4,303	\$4,303
Water heaters	\$2,087	\$4,933	\$18,886	\$23,807	\$4,921
<i>Residential total</i>	<i>\$13,580</i>	<i>\$19,962</i>	<i>\$39,379</i>	<i>\$126,803</i>	<i>\$87,424</i>

Although it is clear that the residential sector has great potential to offer energy savings, most of the studies that look at the savings potential in the residential sector seldom frame their results and analysis at an economy-wide level. The EPPA model is apt for understanding policy changes at an economy-wide level; hence, this lead to a desire within the research group to model demand-side technology changes using EPPA's CGE framework, explained in further detail in the next chapter.

3. Methodology

In this chapter I describe the Emissions Prediction and Policy Analysis (EPPA) model, the method used to analyze the research question. I briefly explain the functioning of the EPPA model and then explain how changes and additions are made to the model to address the specific research question. Changes are made to the existing household consumption sector in order to develop a distinction between consumption for HVAC purposes and for other household energy needs. I then provide an explanation of how new electric HVAC technologies are introduced and how underlying data on such technologies is translated into model parameters.

3.1 Background of the EPPA Model

The MIT Emissions Prediction and Policy Analysis (EPPA) model has been used extensively to study energy and climate change policies. EPPA is a recursive-dynamic CGE model that captures global economic activity through 'Regions' that represent different geographical areas and 'Sectors' that capture economic activity in different industries. As shown in figure 12, the model creates relationships between consumers and producers and allows for trade to take place between the different regions of the model. The model dynamically solves for prices and quantities of the various markets (both international and domestic) to provide an equilibrium solution for all goods. The model is written in the General Algebraic Modeling System (GAMS) language and uses Mathematical Programming System for General Equilibrium (MPSGE) to solve (Rutherford, 1995).

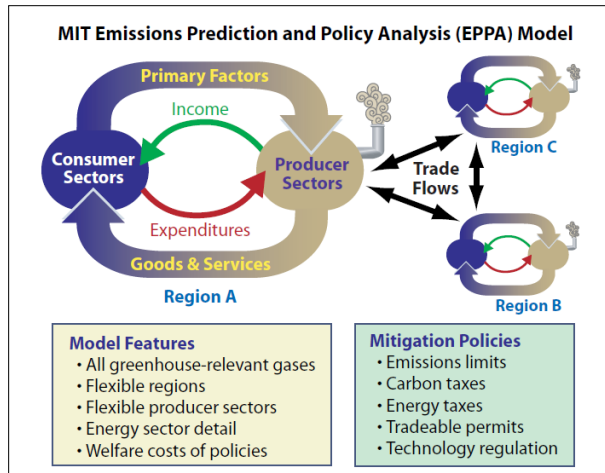

Figure 12 - MIT Emissions Prediction and Policy Analysis (EPPA) Model (Paltsev et al., 2005)

Extensive documentation on the model is available online at the website of the Joint Program on the Science and Policy of Global Change at MIT (<http://globalchange.mit.edu/>). Although the most recent documentation is that of EPPA4, the most up-to-date version of the model (EPPA5) utilizes the same functional structure as described in (Paltsev et al., 2005). EPPA5 uses 2004 as a benchmark year to check the model for consistency with the Global Trade Analysis Project (GTAP) data set and then solves recursively from 2005 onwards with a 5 year step. Using the GTAP data set, the model is broken down in 16 regions and 14 sectors as shown in the table below.

Table 6- The EPPA Model: Regions and Sectors

REGIONS	SECTORS
United States (US)	Agriculture-Crops (CROP)
Canada (CAN)	Agriculture-Livestock (LIVE)
Mexico (MEX)	Agriculture-Forestry (FORS)
Japan (JPN)	Food Products (FOOD)
Australia and New Zealand (ANZ)	Coal (COAL)
Europe (EUR)	Crude Oil (OIL)
Eastern Europe (ROE)	Refined Oil (ROIL)
Russia Plus (RUS)	Gas (GAS)
East Asia (ASI)	Electricity (ELEC)
China (CHN)	Energy Intensive Industries (EINT)
India (IND)	Other industries (OTHR)
Brazil (BRA)	Services (SERV)
Africa (AFR)	Transport (TRAN)
Middle East (MES)	Savings Good (CGD)
Latin America (LAM)	
Rest of Asia (REA)	

3.2 Functionality of the EPPA Model

In the section below, I briefly describe the working of the EPPA Model. The functionality of the model is important to keep in mind as it is used later in the thesis to identify some of the advantages and limitations of using this methodology to address the research question.

3.2.1 Equilibrium Structure

In order to reach an equilibrium solution in EPPA, there are three conditions that need to be satisfied. These conditions are explained below and have been summarized from documentation about the EPPA Model (Paltsev et al., 2005):

- **The Zero Profit Condition**

$$\mathbf{profit} \geq \mathbf{0}, \mathbf{y} \geq \mathbf{0}, \mathbf{output}^T(-\mathbf{profit}) = \mathbf{0} \quad (1)$$

This condition implies that any activity taking place must earn profits that are equal to zero provided activity occurs at a positive level(y). ' $\mathbf{output}^T(-\mathbf{profit}) = 0$ ' implies that this condition holds true across all sectors in all regions during equilibrium.

- **The Market Clearance Condition**

$$\mathbf{supply} - \mathbf{demand} \geq \mathbf{0}, \mathbf{p} \geq \mathbf{0}, \mathbf{p}^T(\mathbf{supply} - \mathbf{demand}) = \mathbf{0} \quad (2)$$

This condition requires that for every good produced, demand for the good may not exceed the supply. It requires that for each such good with a price greater than zero, the supply must equal the demand. For any good that is produced in excess, the price must be zero.

- **The Income Balance Condition**

$$\mathbf{income} = \mathbf{endowment} + \mathbf{tax\ revenue} \quad (3)$$

This condition ensures that there is balance between income and expenditure, by stating that the amount of income must sum the amount of endowment and tax revenue received.

With these three conditions holding true in equilibrium across all sectors and regions, the model takes the form of a mixed complementarity problem (MCP) (Mathiesen, 1985) (Rutherford, 1995) to solve for a market equilibrium.

3.2.2 Production Structure

Production and Consumption structures in the EPPA model are created using nested Constant Elasticity of Substitution (CES) functions, including Cobb-Douglas and Leontief special cases. The nesting structure allows for intermediates that are required in production to be substituted with other suitable intermediates before rising in the nesting chain. For any production block that requires energy as an input, all primary energy goods are typically aggregated into a 'Non-Elec' (see figure below) input at the lowest level. This is nested with electricity to form a composite 'Energy Aggregate'. In most cases, energy is then substitutable with a capital and labor nest, referred to as the 'Value-Add' nest. This entire nesting structure is substitutable with other intermediate inputs. The production structure of refined oil is shown below to better illustrate production blocks in the EPPA model.

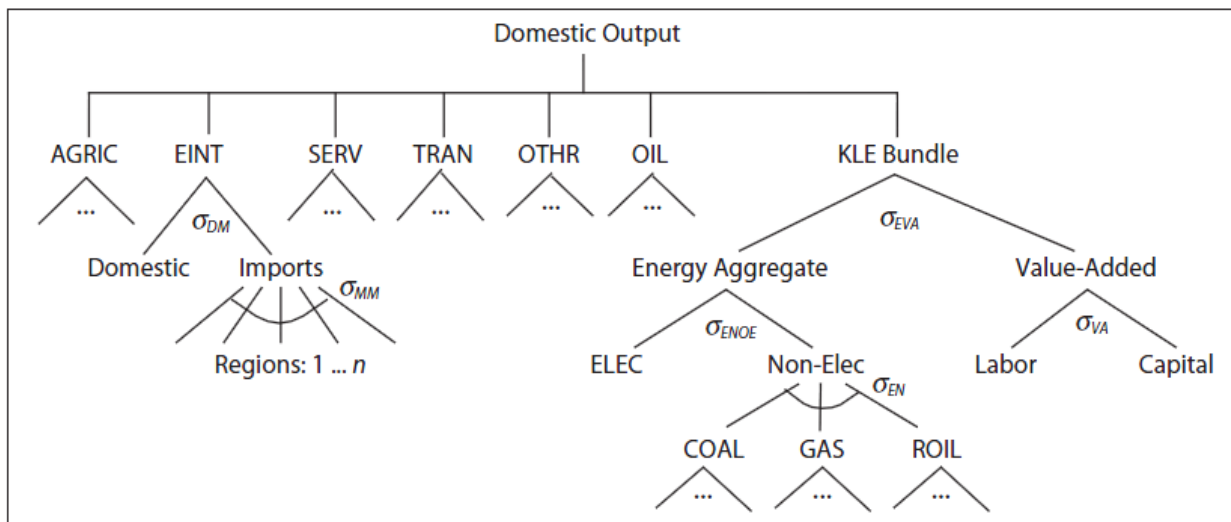

Figure 13- Refined Oil Production Structure in the EPPA Model (Paltsev et al., 2005)

3.2.3 Consumption Structure

Consumption blocks in the model also take the form of CES functions. Within the household consumption block (shown in the figure below), energy consumption occurs at a single level with

substitution amongst different forms of energy inputs. Non-energy goods include all non-transport, non-energy related goods. Combined with household energy consumption they form a composite 'other consumption' (see figure below) good that along with the composite transportation nest represents total household consumption. For more information on the consumption and production structures in EPPA, refer to (Paltsev et al., 2005).

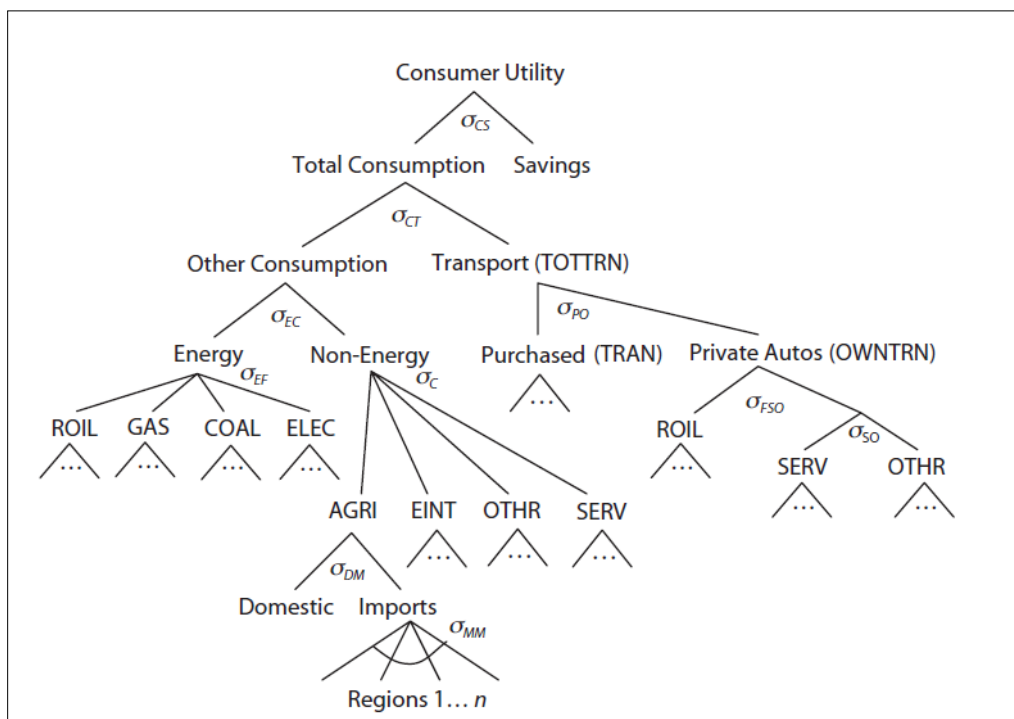

Figure 14 - Consumption Structure in the EPPA Model (Paltsev et al., 2005)

3.2.4 Policy Constraints

Recent improvements in the EPPA model provide the ability to simulate a variety of different policy cases – whether global or regional, sector-specific or multi-sectoral. Using the EPPA model, one can mix policies across regions and also set up emissions trading across regions. The flexibility provided by the model in testing different policies has proved beneficial even when pre-existing distortions impact particular policies (Babiker, Metcalf, & Reilly, 2003), (Paltsev *et al.*, 2005). Along with the ability to represent taxes and subsidies exogenously, one can also use the model to endogenously constrain emissions (whether CO₂ only or all GHG gases). More information on this mechanism can be found in (Jacoby & Ellerman, 2004).

3.3 Household Consumption Modeling

In the section below I describe the pre-existing structure of household consumption in the EPPA model and then introduce the changes made to the model to represent HVAC and non-HVAC technologies, along with advanced electric HVAC options.

As shown in the previous figure, total consumption in the household sector is a combination of consumption for transportation purposes (Paltsev, Viguier, Babiker, Reilly, & Tay, 2004) and other consumption. Other consumption comprises two forms; energy and non-energy respectively. Non-energy consumption represents the consumption of agriculture, services, etc. An elasticity of substitution in the model represents the ability of household consumers to switch between these forms of non-energy consumption.

With regards to household energy consumption, households substitute between electricity and non-electric inputs (refined oil, gas or coal). As per the latest version of the model (EPPA5), this elasticity of substitution is fixed at 0.4 across different regions. This signifies that for all energy consumption decisions made at the household level, consumers partially substitute between electricity and other fuels for end-use consumption. More information on the final demand elasticity can be found in (Paltsev et al., 2005). Although the model is benchmarked with 2004 GTAP data, the sector is not modeled to capture energy consumption by category i.e. consumption for heating, cooling, appliances etc. Hence, this structure is not ideal for testing specific technology or policy changes that impact a particular household energy consumption category (such as the impact of new heat pump technologies or policies that support weatherization, etc.).

Keeping that in mind, three main steps are carried out to enhance the model in order to address the research question:

- Breakdown of household energy consumption into consumption of HVAC and other applications
- Modeling of technology advancements that impact HVAC consumption
- Implementation of policy cases that either proliferate or inhibit the advanced end-use electric technologies

3.3.1 Application Based Consumption Blocks

In order to capture the impact of advanced residential electric HVAC technologies, as explained earlier, I split household energy consumption into two application based blocks:

- Heating and Cooling (referred to as HVAC in the model)
- Other applications (referred to as NHVAC in the model)

This is a first step toward breaking down the consumption blocks in the model into those that replicate household consumption of energy, such as space heating, space cooling, water heating and appliances respectively. Given the functioning of the EPPA model, breaking down the sector into the HVAC and other applications block required the following steps and calculations:

- The split between energy consumption for HVAC and for other applications

The table below shows consumption quantities (in Quad Btu) for the different end-use applications. Heating and cooling are responsible for about 70% of end-use residential energy consumption. Given that the base year of the model is 2004, the new heating and cooling sector is initially assigned 71% of household energy consumption whereas the other is assigned 29% to begin with based on the numbers shown below.

Table 7 - End-Use Energy Consumption in the U.S. Residential Sector

Year	Space Heating (Quad Btu)	Air Conditioning (Quad Btu)	Water Heating (Quad Btu)	Appliances (Quad Btu)	Heating and Cooling Share
1997	5.61	0.42	1.92	2.72	74.5%
2001	4.98	0.62	1.69	2.94	71.3%
2005	4.73	0.88	2.12	3.25	70.4%

- HVAC Consumption Block

The HVAC block is modeled to represent the choices consumers face with heating and cooling equipment. Consumers select the equipment (and pay for the equipment and installation costs) and then consume and pay for the corresponding fuel being used. The consumption block shown in the figure below is a representation of the fuel and non-fuel costs associated with consuming HVAC

equipment. In the model, the cost of the equipment and the installation cost are represented as a service. As the cost of fuel rises, consumers could either consume less of the same fuel or decide to switch to different equipment with lower fuel costs.

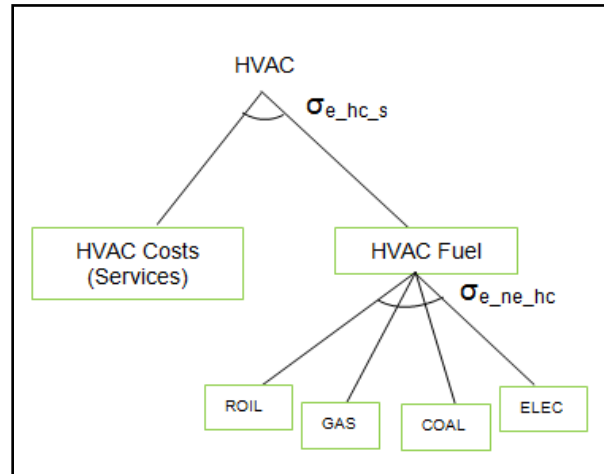

Figure 15- New Heating and Cooling Consumption Block

$\sigma_{e_hc_s}$ represents the ability for consumers to switch their HVAC equipment as the costs of the fuel change. Given that consumers tend to think of their HVAC equipment as sunk costs and often face the principal-agent problem whereby they are not directly responsible for purchasing HVAC equipment, $\sigma_{e_hc_s}$ has been assigned a low elasticity value of 0.2 Sensitivity analysis on this elasticity is carried out and explained further in Chapter 4.

$\sigma_{e_ne_hc}$ is meant to represent the ability of consumers to substitute between electric and non-electric forms of energy consumption for residential heating and cooling purposes. Household cooling primarily comes from electricity whereas heating comes from either the use of electricity or gas. As it can be seen in table 8 below, natural gas and electricity combined are responsible for fueling about 90% of heating energy requirements in the U.S.

Table 8 - Space Heating and Water Heating Consumption in the U.S. by Energy Source (EIA, 2012)

Space Heating by Source in 2009		Water Heating by Source in 2009	
Natural Gas	50%	Natural Gas	51%
Electricity	35%	Electricity	41%
Liquefied Petroleum Gases	5%	Liquefied Petroleum Gases	4%
Distillate Fuel Oil	6%	Distillate Fuel Oil	3%
Wood	2%	Other or No Water Heating	1%
Other or No Equipment	1%		

Hence, when evaluating the ability to substitute between electric and non-electric forms of energy for heating and cooling applications, one is essentially computing the ability to substitute between electricity and gas as end-sources of energy in the household sector. The elasticity of substitution $\sigma_{e_ne_hc}$ calculated and used in this model is 1.2. This value is based on an assessment of existing literature - (Dubin & McFadden, An Econometric Analysis of Residential Electric Appliance Holding and Consumption, 1984), (Liao & Chang, 2002), (Alberini, Gans, & Velez, 2010), (Dubin, Miedema, & Chandran, 1986), (Davis, 2008) - that have looked at the elasticities of household gas and electricity consumption.

- NHVAC Consumption Block

In the pre-existing model, substitution between the different fuels used for household energy consumption was assigned an elasticity of 0.4. This number represented the ability to switch between electric and non-electric forms of energy for all types of energy consumption in households. In the NHVAC block, as shown in the figure below, $\sigma_{e_ne_nhc}$ is also used to represent the ability to substitute between electric and non-electric forms of end-use energy; however, this elasticity is limited to forms of household energy consumption that are not heating or cooling related. Intuitively speaking, given that heating and cooling is excluded from this specific elasticity (and keeping in mind that fuel-switching is more likely in heating applications), it can be argued that $\sigma_{e_ne_nhc}$ should have a value lower than 0.4. A value of 0.3 is selected for the elasticity and sensitivity analysis is carried out for the same. The sensitivity analysis indicates that the model structure is insensitive to $\sigma_{e_ne_nhc}$.

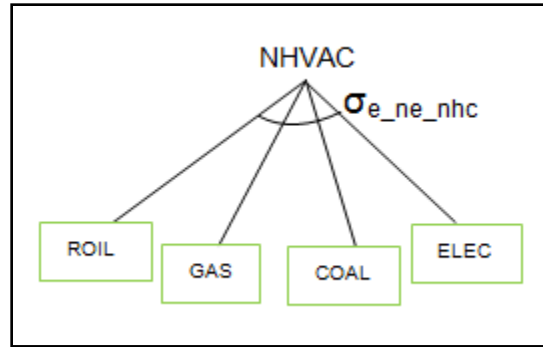

Figure 16 - Consumption Block for Non-HVAC Household Consumption

3.3.2 Modeling New HVAC Technologies

Given that household consumption in the model is split into HVAC consumption and other applications respectively, specific technology changes also have to be introduced that can impact either of the two blocks. In this section below, I explain how new electric HVAC technologies are introduced to and evaluated in the model.

In the EPPA model, exogenous technology changes or advances are modeled as ‘backstop’ technologies (Jacoby et al., 2006), (Paltsev et al., 2005). Backstop technologies have been used extensively in the EPPA model in the past, although primarily to represent advanced energy supply options (examples include shale oil extraction, carbon capture and sequestration and integrated coal gasification combined cycle technology). These technologies, although modeled exogenously, enter endogenously when and if they become economically competitive with existing technologies. This calculation is made by the model taking into account prices that are determined by resources, usage and policies that impact a sector or the economy in general. For example, carbon capture and sequestration technology may endogenously enter into the market if a carbon price is high enough to enable the technology to be economically competitive.

The method of modeling new technologies involves understanding the break-down of costs and inputs of the new technology (input shares) and understanding the factor by which new technologies are more expensive to begin with than the existing technologies (mark-up). Also, for several technologies, a certain fixed factor input is modeled to indicate their rate of penetration. Explained in further detail in (Jacoby et al., 2006), it is noted that new technologies penetrate the market gradually rather than

instantaneously. Typically, there is limited expertise or engineering capacity for a new technology that prevents it from capturing an entire market instantaneously. The fixed factor does not impose an absolute limit on the ability to expand production for a new technology but, based on the principle that a firm may need to expand more than originally planned or hire non-expert staff to meet increased levels of production, it implies that beyond a certain threshold of production any new technology will see an increase in costs, slowing its penetration until capacity to deliver it expands.

- **Input Shares and Mark-ups**

In the EPPA model, every backstop technology is represented using normalized input shares and a mark-up factor. The normalized input shares typically break-down the lifetime cost a certain technology into factors such as capital, labor, fuels, etc. Mark-ups on the other hand are used to indicate the factor by which the new technology is more expensive than technology currently existing in the market. The mark-up factor and input shares for new heating and cooling technologies used are as follows:

Table 9 - Mark-up and Fixed Factors for New Heating and Cooling Technologies

Mark-up Factor	Normalized Input Shares		
	Services (Equipment and Installation Costs)	Electricity	Fixed Factor
1.15	0.35	0.6	0.05

To calculate the mark-up factor, the National Renewable Energy Laboratory’s (NREL) National Residency Efficiency Measure Database is used³. The database provides a list of new technologies and their efficiencies and compares their costs to existing technology. It makes it possible to look for mature as well as upcoming technologies with similar specifications and hence provides for a valid comparison. However, given that it covers multiple technologies within the heating and cooling space, an aggregate of sorts is used to come up the mark-up factor. Looking at most technologies, the factor could vary anywhere from 1.1 to 1.5.

To calculate the input shares, the NREL database cited above is used along with the Department of Energy’s (specifically the Office of Energy Efficiency and Renewable Energy’s) life cycle cost estimate

³ The database can be accessed at <http://www.nrel.gov/ap/retrofits/>

tools⁴. The tools provide consumers the options to look at higher efficiency equipment and calculate the life-cycle costs, including the capital and operational costs. Once again, the numbers chosen represent an estimate or aggregate of sorts and do not hold true for every case. Consequently, some sensitivity analysis is carried out on the input shares, specifically on the fixed factor input.

- **Other Model Parameters for New HVAC Technologies**

Backstop technologies in the EPPA model are set up in a way such that the basic inputs of producing the technology (capital, labor, etc.) are substitutable to an extent with a certain resource or constraint. For example, when producing wind farms, land may be the constraint that determines the production of the technology. This production structure is also limited by a fixed factor as explained earlier. Typically, each such backstop technology block is characterized by three elasticities of substitution (shown in the figure below):

- σ_{FVA} – This indicates the ability to substitute between the fixed factor and the inputs of the new technology in question.
- σ_{RVA} – This is used to represent the ability to substitute between a resources (electricity in the case of new heating and cooling technologies used in this thesis) and a mix of other inputs such as capital, labor and services.
- σ_{VAO} – This represents the elasticity of substitution between the primary inputs of the new technology i.e. the ability to substitute between capital, labor, etc to produce the technology.

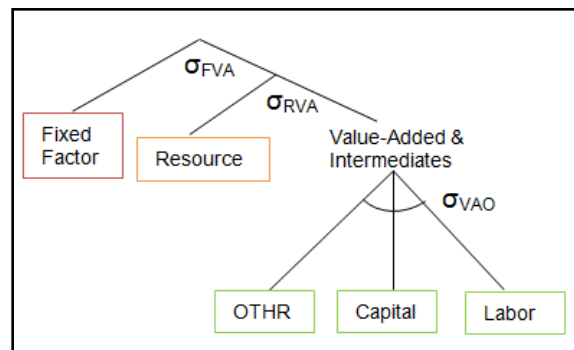

Figure 17 – Typical Backstop Technology Production Block in the EPPA Model

⁴ The tools can be found at http://www.energysavers.gov/your_home/

The elasticities for new heating and cooling technologies are selected by analyzing previous backstop technology elasticities in EPPA. The values assigned to these elasticities are as follows:

- $\sigma_{FVA} - 0.9$
- $\sigma_{RVA} - 0.1$
- $\sigma_{VAO} - 1.0$

For more information on these elasticities and their values for other backstop technologies in the EPPA model please refer to (Paltsev et al., 2005).

3.3.3 Policy Implementation

Given the 15% mark-up in new technologies explained in the previous section, the proliferation of new technologies into the market requires certain incentives or policy interventions. In order to understand the impact of advanced electric HVAC technologies on the residential sector as well as the economy in general, below is the list of indicators that have been evaluated. Household indicators include:

- **Household Electricity Consumption**
- **Household Gas Consumption**
- **Household Emissions**

The following economy wide indicators have been evaluated:

- **Total Electricity Consumption**
- **Total GHG Emissions**

These indicators provide insight into the main questions of fuel-switching between electricity and gas in households, changes in energy consumption and the impact of these technologies on emissions abatement. Consequently, the following policy cases are analyzed to provide insight into household and economy-wide implications of end-use electrification.

- **Electricity subsidy worth 25% of electricity prices**
- **25% reduction in new equipment capital costs**
- **Economy-wide low carbon price** - \$12/ton CO₂ equivalent in 2004 dollars and growing at a rate of 4% per annum, beginning in the year 2015

- **Economy-wide high carbon price** - \$32/ton CO₂ equivalent in 2004 dollars and growing at a rate of 4% per annum, beginning in the year 2015

The first and second cases represent policies that directly impact residential consumer choices whereas the third and fourth represent policies that have more of a direct impact on the economy in general. Some of the cases are combined with others in order to understand the implications of combining economy-wide and household specific policies.

4. Results

In this chapter, I describe the results obtained from the enhanced EPPA model. To begin with, the enhanced model is compared to the pre-existing model. Following this, I describe the results obtained from the different policy cases and highlight specific energy and economic indicators. Keeping in mind that the model is sensitive to certain parameters that are changed and introduced, this chapter also includes a discussion on the sensitivity of the model to some of those parameters.

4.1 Enhanced Base Model

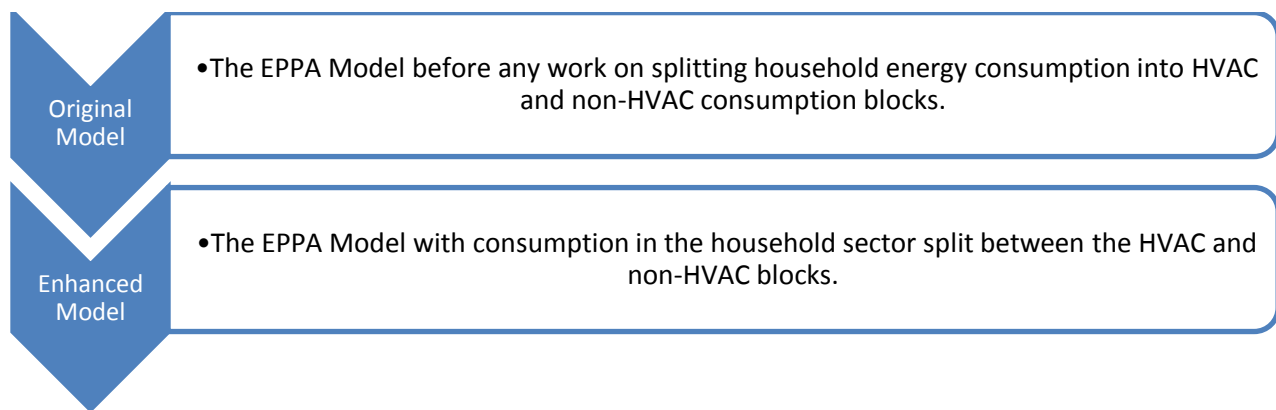

Figure 18 - Description of the EPPA Model Changes

As described in the figure above, the enhanced model is meant to provide a more detailed representation of HVAC consumption in households. To begin with, the enhanced model is compared to the pre-existing model on the basis of the following indicators:

- Household Electricity Use and Total Electricity Use

The first indicator is meant to check if any changes are seen in specific household energy consumption patterns whereas the latter serves as an indicator representative of the larger economy.

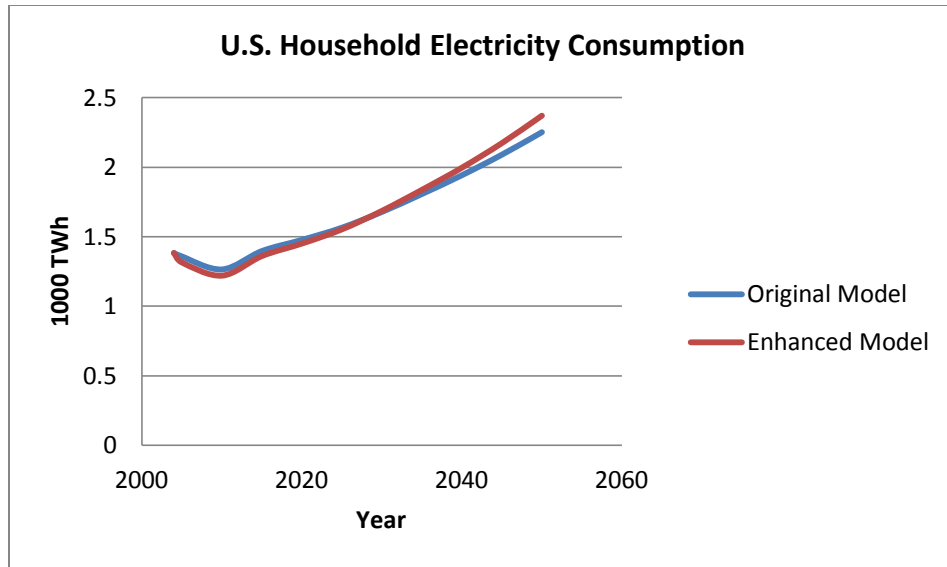

Figure 19 - U.S. Household Electric Consumption (Original vs. Enhanced Model)

As seen in the figure above, household energy consumption in the enhanced model exceeds that in the original model beginning around 2035.

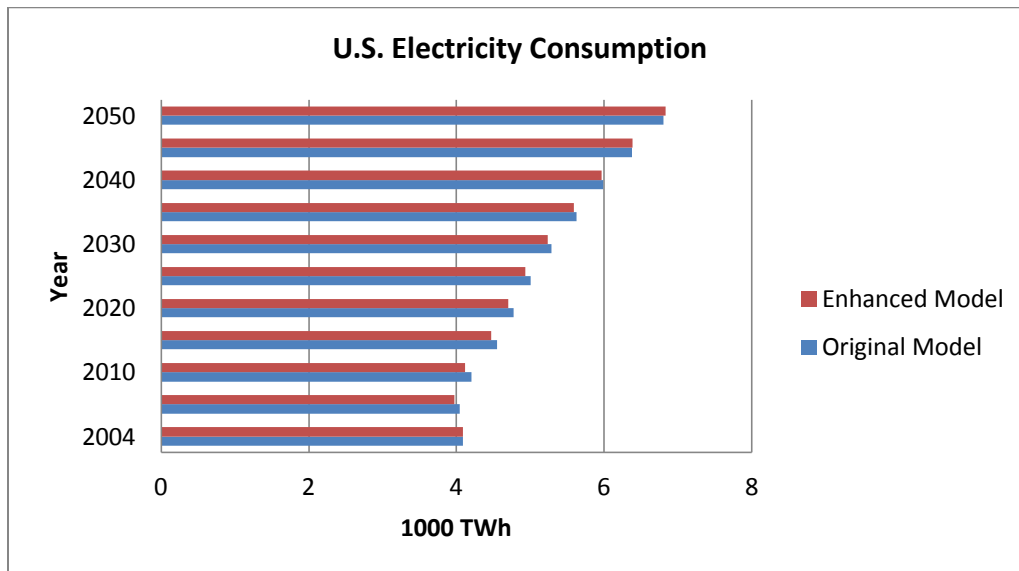

Figure 20 - U.S. Total Electricity Consumption (Original vs. Enhanced Model)

As the figure indicates, total U.S. electricity consumption in the enhanced model exceeds that in the original model in around 2040. In both the indicators reported, the enhanced model initially shows lower levels of household and total electricity consumption. However, electricity consumption in the enhanced model begins to exceed that in the original model close to 2040. This indicates that electric

HVAC equipment, modeled in the enhanced model, becomes competitive over time as the price of electricity drops relatively compared to the price of other fuels. Hence, consumers switch to electric HVAC equipment over time and hence the figures show increased levels of household and economy-wide electricity consumption.

4.2 Policy Cases Analysis

As described in Chapter 3, there are a total of four distinct policies that are tested on the model in order to understand the impact of end-use electrification:

- **Subsidizing household electricity prices by 25%**
- **Economy-wide Low Carbon Price beginning in 2015**
- **Economy-wide High Carbon Price beginning in 2015**
- **25% reduction in new equipment capital cost**

Along with this, the indicators examined are divided into household specific indicators and economy wide indicators in order to gain an understanding of the specific impacts on the household sector as well as on the larger economy.

4.2.1 Household Indicators

Three specific household indicators have been selected to test the impact of the policy changes. These indicators are the following: household electricity consumption, household gas consumption and household emissions.

- **Household Electricity Consumption**

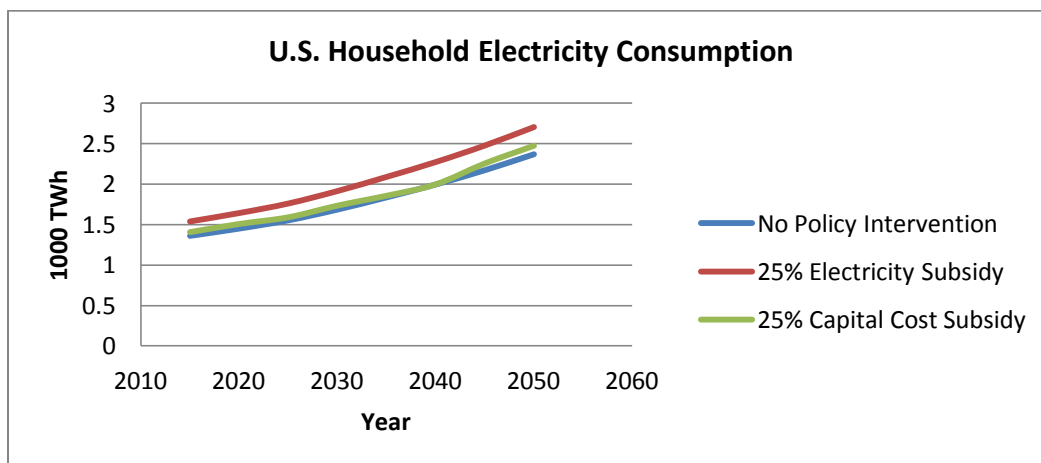

Figure 21 - Model Results - U.S. Household Electricity Consumption

Looking the figure above, the green line i.e. the ‘25% Capital Cost Subsidy’ can only be distinguished from the blue i.e. the ‘No Policy Intervention’ case in the latter half of the time-scale. This gives the impression that subsidizing the cost of the new heating and cooling appliances may not lead an immediate proliferation of new HVAC equipment. This could be because of the limited ability of households to switch to new equipment or indicate that the fuel costs are the main driver behind such decision choices – a result that is further indicated by red line in the graph. Subsidizing electricity however leads to an increase in the consumption of household electricity and the proliferation of new electric HVAC equipment.

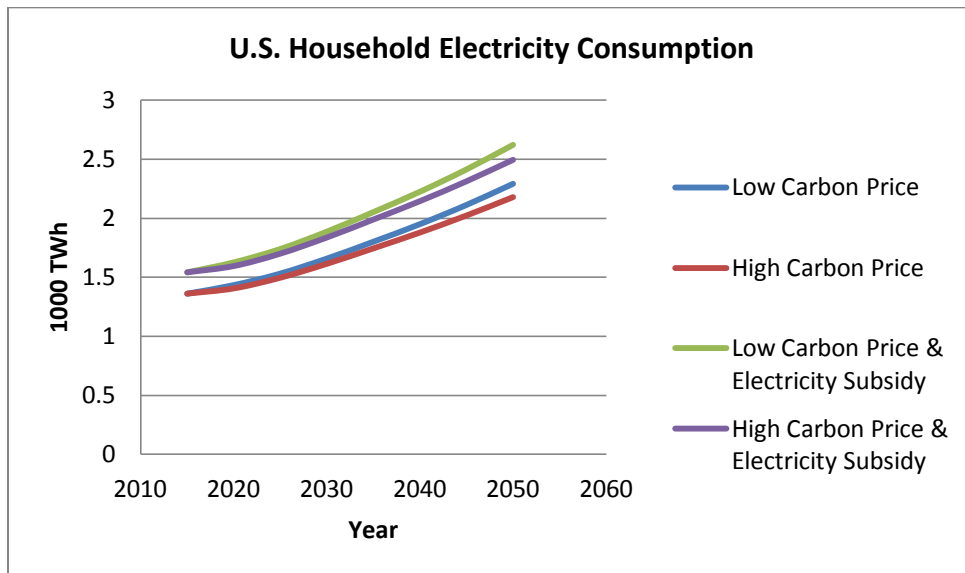

Figure 22 - Model Results - U.S. Household Electricity Consumption

If a carbon tax is imposed on the economy, as expected, there would be a decrease in electricity consumption at the household level. However, policies that incentivize households to purchase efficient electric appliances may lead to an increase in electricity use and hence counter any household electricity reductions seen from a carbon policy. This certainly does signify that any economy wide policy should be thought of alongside any pre-existing household electricity policies in order to understand the impact resulting from the interaction between the two.

- Household Gas Consumption

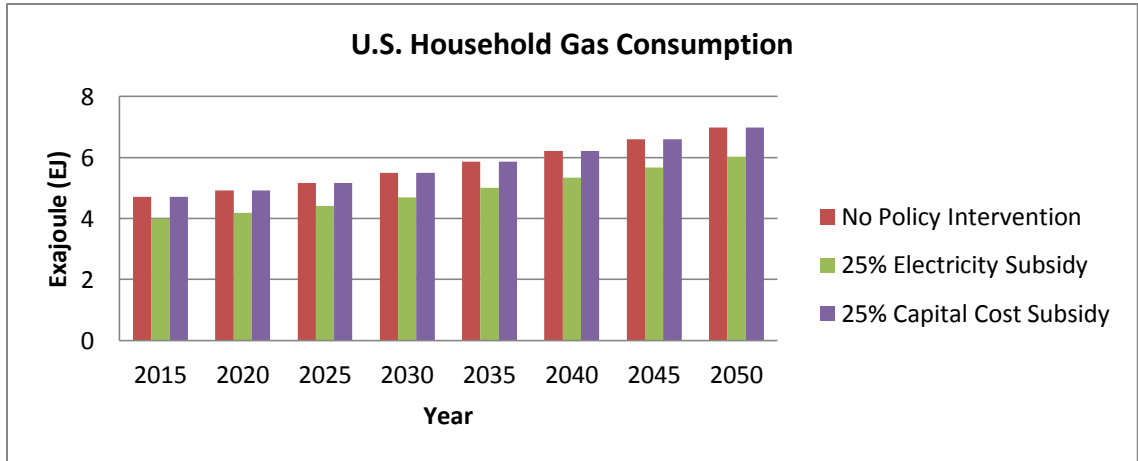

Figure 23 - Model Results - U.S. Household Gas Consumption

Applying the same policy cases, it can be seen that subsidizing the cost of electricity reduces gas consumption, indicating that a switch takes place between end-use gas consumption and electricity consumption. Gas consumption seems to decrease about 10% whereas electricity consumption increases a little more than 10%. This certainly provides insight into the possibility of fuel switching from gas to electricity provided policies are implemented that encourage household end-use electrification.

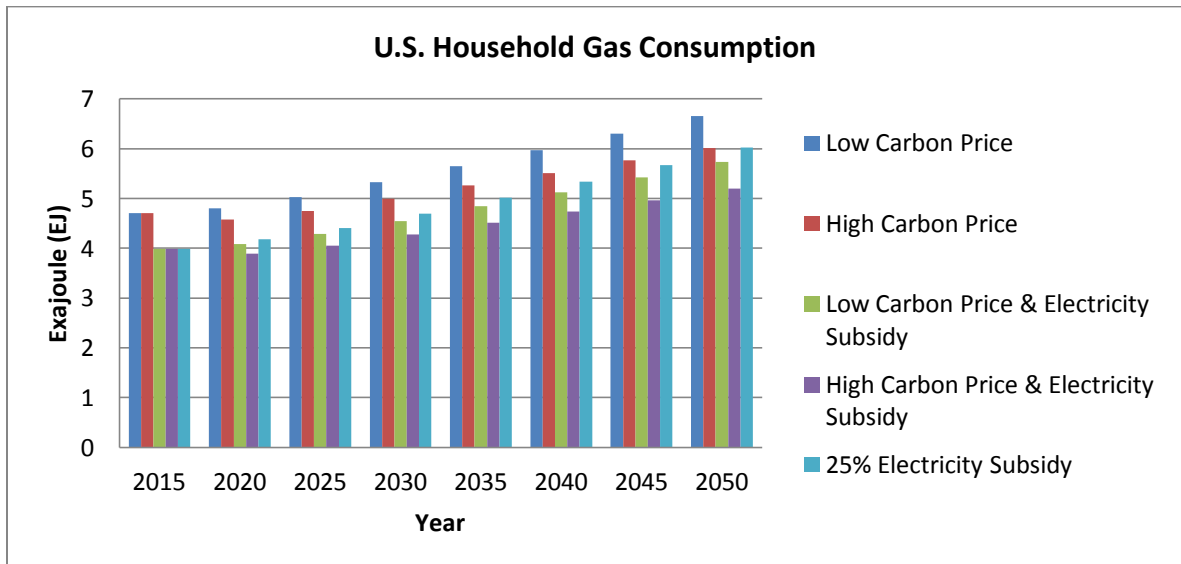

Figure 24 - Model Results - U.S. Household Gas Consumption

As seen in the figure above, all policy cases lead to a decrease in household gas consumption when compared to no policy intervention. Given that incentivizing electricity consumption and the proliferation of high-efficiency electric equipment increase electricity consumption and reduce gas consumption, the next question to answer is whether they leads to an increase or decrease in non-transport related household emissions?

- **Household Emissions**

Table 10 - Model Results – Change in U.S. Household Emissions (%)

Year	25% Electricity Subsidy	Low Carbon Price	High Carbon Price	Low Carbon Price & Electricity Subsidy	High Carbon Price & Electricity Subsidy
2020	-15%	-3%	-8%	-17%	-21%
2025	-15%	-3%	-9%	-17%	-22%
2030	-15%	-3%	-9%	-17%	-22%
2035	-14%	-4%	-10%	-18%	-23%
2040	-14%	-4%	-12%	-18%	-24%
2045	-14%	-5%	-13%	-18%	-25%
2050	-14%	-5%	-14%	-18%	-26%

The table above shows the percentage reduction in U.S. household emissions; comparing different policy cases to the business as usual case i.e. the no policy intervention case. As seen in the table, almost all the different policy cases lead to a reduction in end-use household emissions. However, a 25% electricity subsidy leads to emissions that are even lower than those seen with a low carbon tax. These results indicate that high-efficiency electric appliances replace end-uses of gas and hence reduce direct emissions from households. However, keep in mind that the economy wide emissions may nevertheless increase given that increases in electricity consumption may lead to higher emissions from the power generation sector.

4.2.2 Economy-Wide Indicators

The two indicators used to analyze the economy wide impacts of end-use electrification are total electricity consumption, and total GHG emissions.

- **U.S. Electricity Use**

Consistent with what is seen in the household results section, carbon prices significantly reduce electricity consumption, whereas subsidizing electricity prices lead to an increase in consumption.

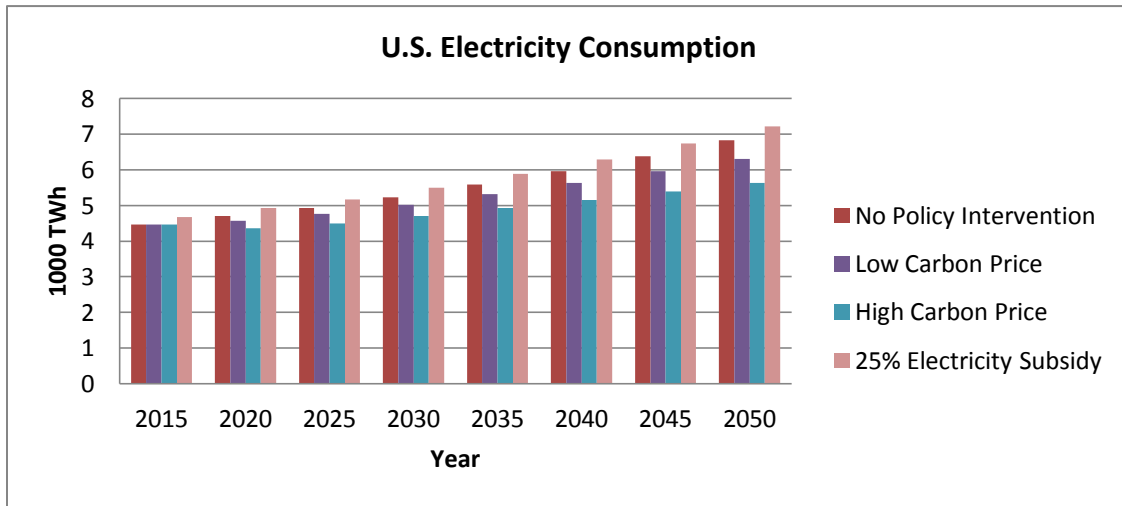

Figure 25- Model Results - U.S. Electricity Consumption

When adding a policy to incentivize electricity consumption along with carbon policy, the decreases in electricity consumption seen from the carbon policy are countered by the increase seen as a result of subsidized electricity prices. As expected, these results fall in line with the results seen for changes in electricity consumption in the household sector.

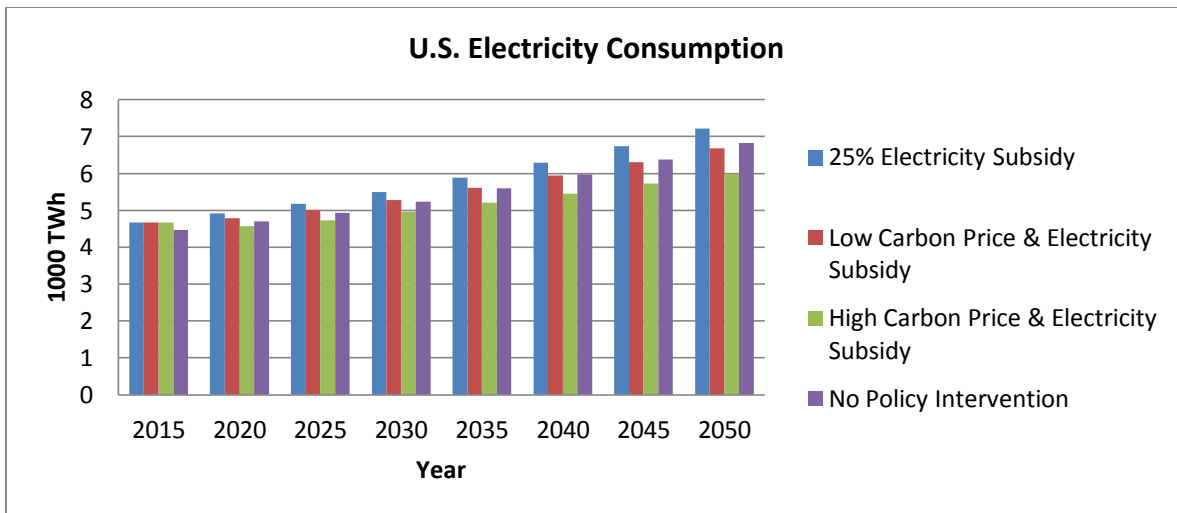

Figure 26 - Model Results - U.S. Electricity Consumption

- **U.S. GHG Emissions**

Although results in the previous section indicated that incentivizing electricity consumption lead to a decrease in household emissions that is greater than the decrease that resulted from a low carbon price, the same does not hold true at an economy-wide level. As the figure below shows, the total emissions actually increase with a subsidy on electricity when compared to any of the other cases.

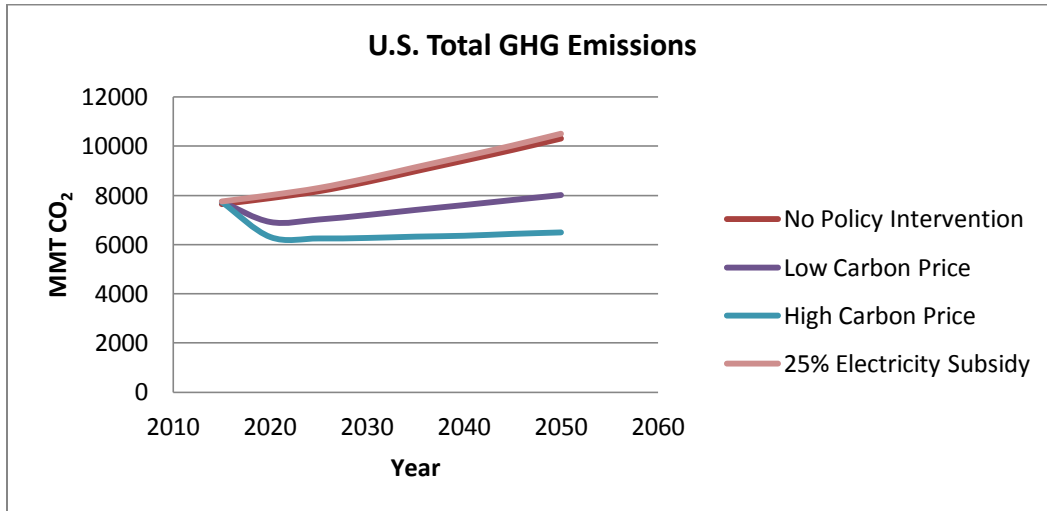

Figure 27 - Model Results - U.S. Total GHG Emissions

This is an interesting result that should be taken note of. Although a variety of studies indicate that the proliferation of high efficiency electric appliances will reduce energy consumption and emissions, the results here indicate that economy-wide emissions actually increase. This is a direct consequence of the power sector fuel mix and hence in order to see the greatest benefits of residential electrification (whether through HVAC technologies or through electric vehicles), policies must be enacted that move the power sector towards de-carbonization.

4.3 Parameter Sensitivity

As explained in Chapter 3, there are a variety of variables that are introduced into the model to capture electric heating and cooling technologies. Chapter 3 identified certain variables for which it would be beneficial to carry out a sensitivity analysis and test their influence on the model results. The variables are:

- $\sigma_{e_hc_s}$ – Elasticity of substitution between services and fuels for HVAC driven household energy consumption (refer to Figure 15).
- $\sigma_{e_ne_nhc}$ - Elasticity of substitution between electricity and non-electric fuels for non-HVAC household energy consumption (refer to Figure 16).
- Fixed Factor Input Share for Electric HVAC Technologies (refer to Table 9).

The rest of this section provides further details on the sensitivities carried out and the results obtained.

- $\sigma_{e_hc_s}$ – Elasticity of substitution between services and fuels for HVAC driven household energy consumption. $\sigma_{e_hc_s}$ is assigned a value of 0.2 in the model and a total of three cases are carried out on $\sigma_{e_hc_s}$
 - Case 1: $\sigma_{e_hc_s} = 0.1$
 - Case 2: $\sigma_{e_hc_s} = 0.2$
 - Case 3: $\sigma_{e_hc_s} = 0.3$

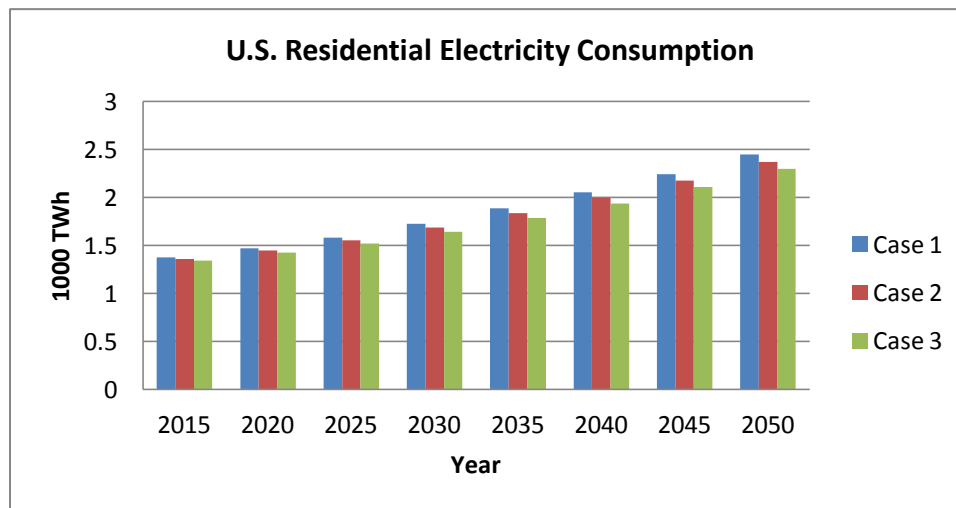

Figure 28 - Sensitivity Analysis - $\sigma_{e_hc_s}$ - U.S. Residential Electricity Consumption

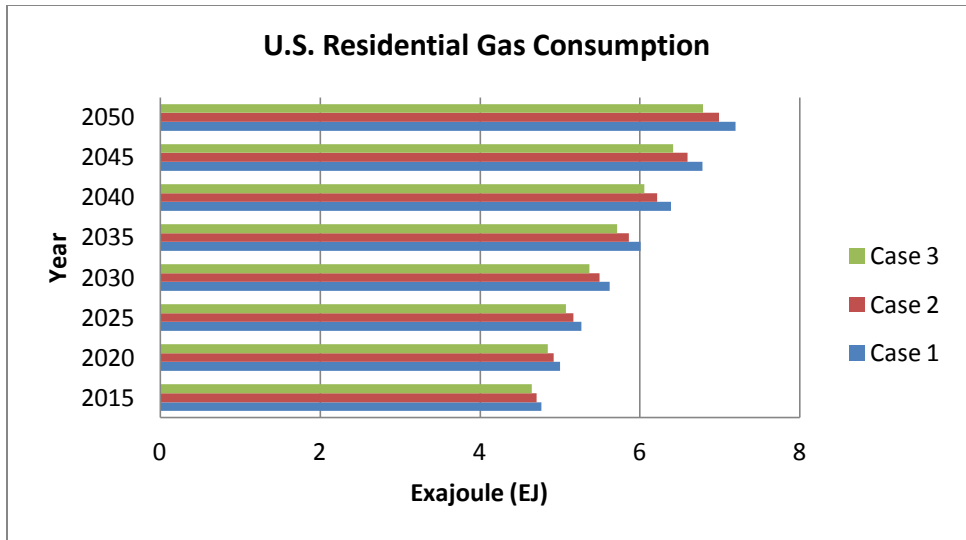

Figure 29 - Sensitivity Analysis - $\sigma_{e_{hc_s}}$ - U.S. Residential Gas Consumption

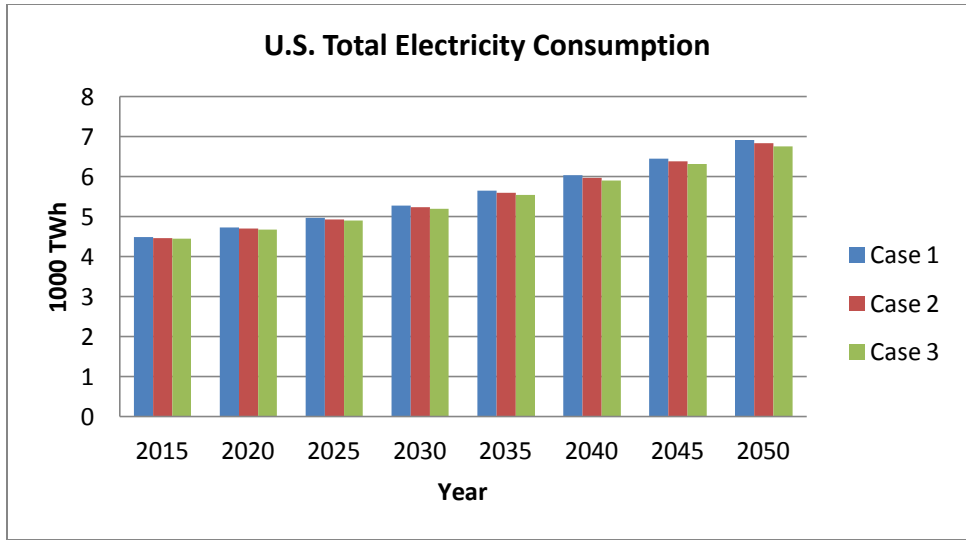

Figure 30 - Sensitivity Analysis - $\sigma_{e_{hc_s}}$ - U.S. Total Electricity Consumption

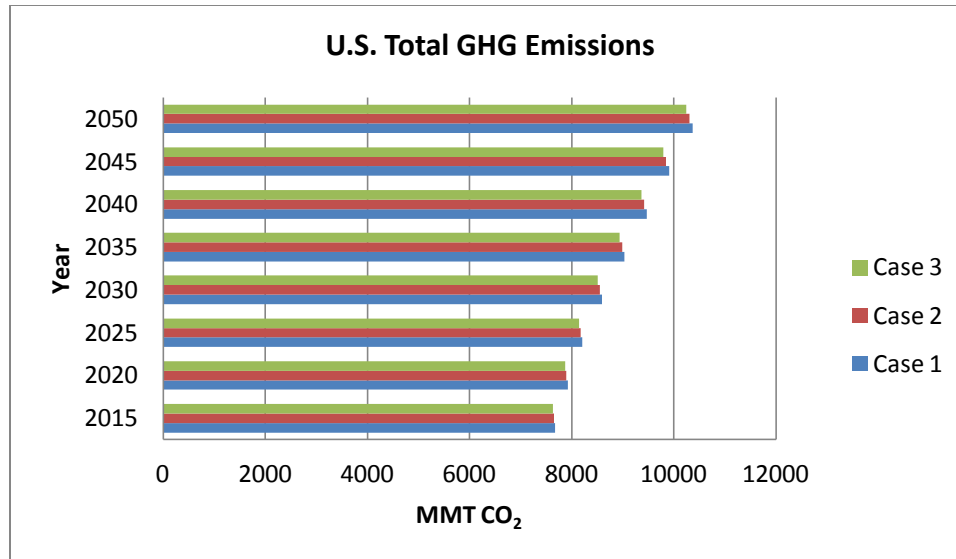

Figure 31 - Sensitivity Analysis - $\sigma_{e_{hc_s}}$ - U.S. Total GHG Emissions

The figures above indicate that the higher the elasticity of substitution, the lower the levels of energy consumption and total emissions. A higher elasticity of substitution allows consumers to switch equipment more easily and move towards cheaper and more efficient equipment over time. However, given the costs and decision-making framework and timelines associated with HVAC buying equipment, I lean on the side of caution towards a lower elasticity of substitution and assign $\sigma_{e_{hc_s}}$ a value of 0.2. However, this certainly is an area that could benefit from further investigation.

- $\sigma_{e_{ne_nhc}}$ - Elasticity of substitution between electricity and non-electric fuels for non-HVAC household energy consumption

As explained in Chapter 3, $\sigma_{e_{ne_nhc}}$ is assigned a value 0.3. To test the sensitivity of this variable, a total of 5 cases are carried out with an elasticity ranging from 0.2 to 0.4 with a step of 0.5. All these cases are run along with a 25% electricity subsidy; the rationale being that a subsidy on electricity consumption would further exaggerate the proliferation of new technologies and help highlight the influence of this elasticity on the results of the model.

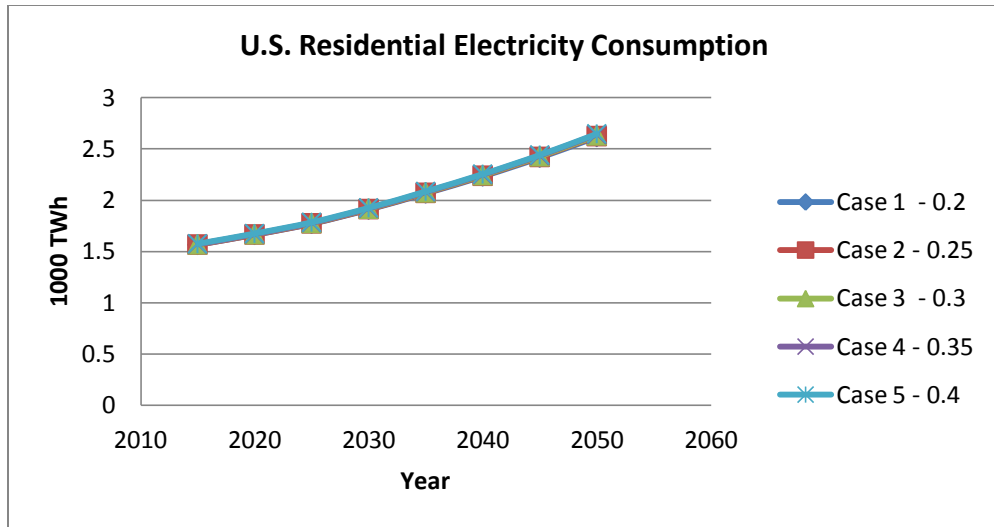

Figure 32 - Sensitivity Analysis - $\sigma_{e_ne_nhc}$ - U.S. Residential Electricity Consumption

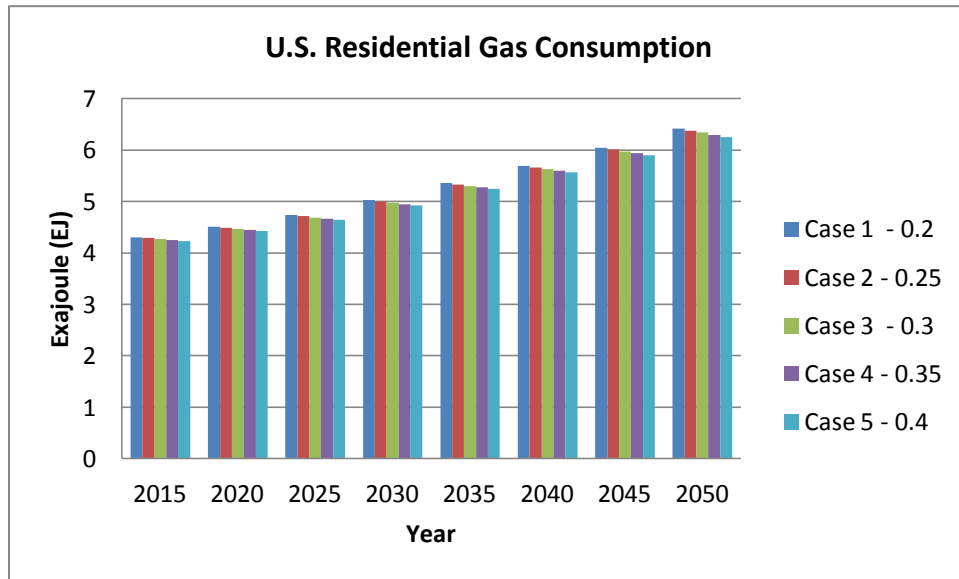

Figure 33 - Sensitivity Analysis - $\sigma_{e_ne_nhc}$ - U.S. Residential Gas Consumption

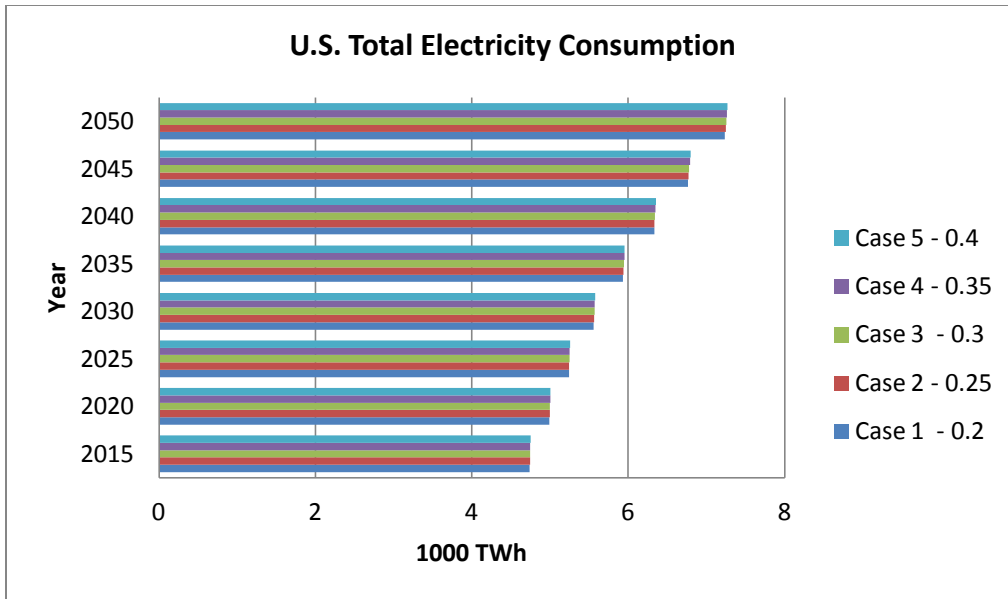

Figure 34 - Sensitivity Analysis - $\sigma_{e_ne_nhc}$ - U.S. Total Electricity Consumption

As the figures above indicate, the model results are not very sensitivity to $\sigma_{e_ne_nhc}$. Looking at indicators for both household characteristics and economy-wide characteristics shows that the model results are not significantly influenced by the elasticity of substitution between electricity and non-electric sources of energy for non-HVAC household consumption purposes.

- Fixed Factor Input Share for Electric HVAC Technologies

The method to calculate the input shares for the backstop technology is described in Chapter 3. The normalized input for the technology is modeled as follows: Services 0.35, Fixed Factor 0.05 and Electricity 0.6.

However, as explained in Chapter 3, there are a wide range of technologies that categorize electric heating and cooling technologies and hence the input shares can vary widely depending on the choice of technology. The sensitivity below modifies the input share of the fixed factor in order to test whether it impacts the rate of growth of new HVAC technologies into the market. Once again, these cases are run along with a subsidy on electricity consumption.

- **Case 1:** Services 0.35, Fixed Factor 0.05 and Electricity 0.6.
- **Case 2:** Services 0.30, Fixed Factor 0.10 and Electricity 0.6.
- **Case 3:** Services 0.25, Fixed Factor 0.15 and Electricity 0.6.

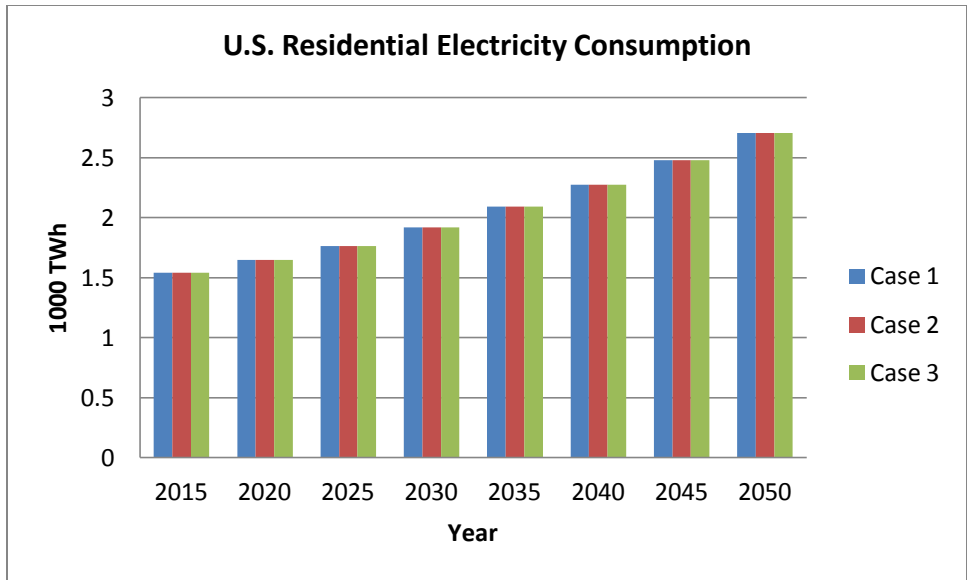

Figure 35 - Sensitivity Analysis –Input Shares- U.S. Residential Electricity Consumption

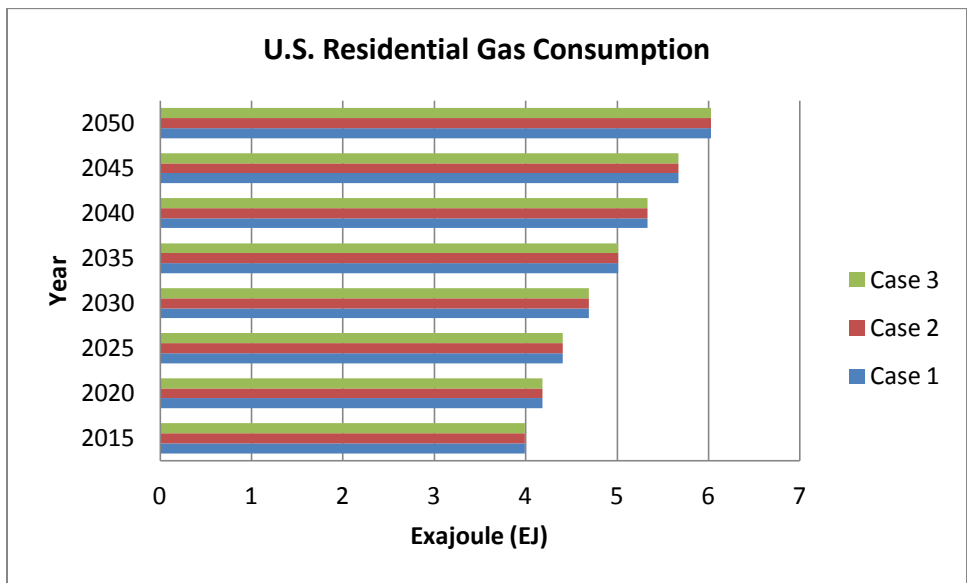

Figure 36 - Sensitivity Analysis –Input Shares- U.S. Residential Gas Consumption

As the graphs above indicate, the model results are insensitive to the fixed factor input share – indicating that other policies and constraints are setting the rate of growth for advanced electric HVAC technologies.

4.4 Comparison to Other Studies

Chapter 2 of the thesis provided the background and motivation for the specific research question and highlighted some of the previous studies in this space. The following section briefly compares the results obtained to some of those studies on two specific grounds: electricity consumption and emissions abatement.

- **Electricity Consumption**

Study Author, Date, and Title	Savings Potential (achievable unless noted)	Timeframe	Annualized Savings	Scope
McKinsey & Company (2009). <i>Unlocking Energy Efficiency in the U.S. Economy.</i>	23% (economic)	2020	~2%/year	<ul style="list-style-type: none"> ▪ National ▪ All fuels ▪ Economic potential only
Ittron (2008). <i>California Energy Efficiency Study.</i> CALMAC Study ID: PGE0211.01	7.5% (electricity) 4.4% (gas)	2016	<1%/year (electricity) ~0.5%/year (gas)	<ul style="list-style-type: none"> ▪ California ▪ Electricity and gas ▪ Technical, economic, and achievable potential ▪ Limited to programs of investor-owned utilities
EPRI (2009). <i>Assessment of Achievable Potential from Energy Efficiency and Demand Response Programs in the U.S. (2010–2030).</i>	5%–8% (realistic to maximum achievable)	2030	<0.5%/year	<ul style="list-style-type: none"> ▪ National ▪ Electricity only ▪ Technical, economic, and achievable potential ▪ Limited to programs; excludes building codes or product standards
WGA (2006). <i>Energy Efficiency Task Force Report. A report of the WGA Clean and Diversified Energy Initiative.</i>	20%	2020	>1%/year	<ul style="list-style-type: none"> ▪ 18 western states ▪ Electricity only ▪ Achievable potential only
ACEEE (2008). <i>Energizing Virginia: Efficiency First.</i>	19%	2025	>1%/year	<ul style="list-style-type: none"> ▪ Virginia ▪ Electricity only ▪ Achievable potential only
Georgia Environmental Facilities Authority. 2005. <i>Assessment of Energy Efficiency Potential in Georgia.</i>	2.3%–8.7% (electricity) 1.8%–5.5% (gas)	2010	~1%/year (electricity) ~0.7%/year (gas)	<ul style="list-style-type: none"> ▪ Georgia ▪ Electricity and gas ▪ Technical, economic, and achievable potential

Figure 37 - Efficiency Related Electricity Savings Potential (Chandler, 2010)

(Chandler, 2010) carried out an analysis in which 20 different energy efficiency studies were evaluated and compared on the basis of their electricity savings potential. The figure above indicates that the

study found that electricity savings could range from 0.5% to 2.0% per year depending on the scope of the policies enacted and the incentives provided to promote energy efficiency.

However, results from the model (shown below), indicate that providing a 25% subsidy in electricity prices actually leads to a slight increase in electricity consumption in households. Although that is in contrast to the Chandler study cited above, the policy measures enacted in those studies are more diverse and specific than a direct subsidy on electricity prices. However, this does beg the question of the rebound effect in energy efficiency. (Goldstein, Martinez, & Roy, 2011) provide an overview of rebound effect studies in this space and conclude that in a lot of cases, the diversity of the policies analyzed lead to results that may often differ vastly from other studies in the field.

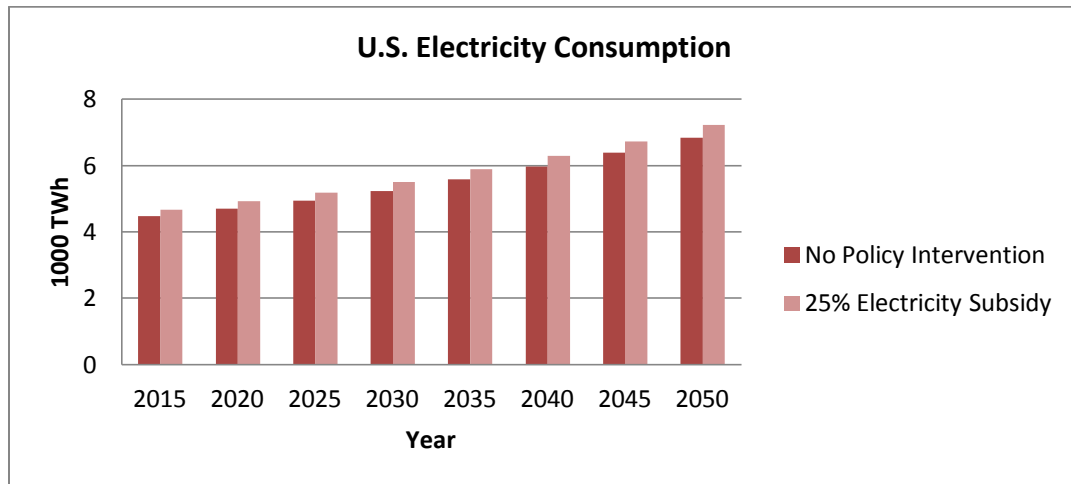

Figure 38 - Model Results - U.S. Electricity Consumption

- **Emissions Abatement**

Studies estimate that the household sector could witness emissions reductions of greater than 25% when compared to a business as usual case. Although different studies look at different levers and hence provide different estimates, almost all agree that the improvement of efficiency in this sector can play an important role in global emissions abatement.

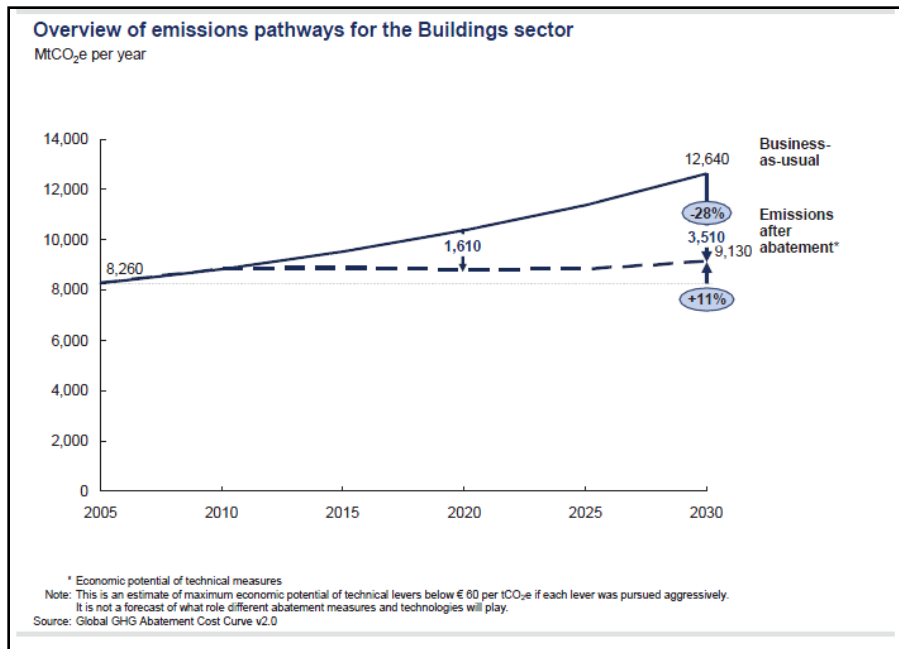

Figure 39 - Potential of Emissions Abatement from the Buildings Sector (McKinsey Global Energy and Materials, 2009)

In a McKinsey study on emissions abatement (see figure above), they find that the buildings sector can experience emissions reductions of 28% by 2030 when compared to a business as usual case. Results from the EPPA also provide a similar outcome. Although the range of reduction varies from 10% to 25%, policies that promote the greater use of electricity reduce GHG emissions from end-uses in the household sector. However, as explained earlier, these policies have different implications at an economy-wide level.

Table 11 - Model Results – Reduction in U.S. Household Emissions (%)

Year	25% Electricity Subsidy	Low Carbon Price	High Carbon Price	Low Carbon Price & Electricity Subsidy	High Carbon Price & Electricity Subsidy
2020	-15%	-3%	-8%	-17%	-21%
2025	-15%	-3%	-9%	-17%	-22%
2030	-15%	-3%	-9%	-17%	-22%
2035	-14%	-4%	-10%	-18%	-23%
2040	-14%	-4%	-12%	-18%	-24%
2045	-14%	-5%	-13%	-18%	-25%
2050	-14%	-5%	-14%	-18%	-26%

5. Future Work & Conclusions

The work carried out in this thesis represents an initial attempt to model demand-side technology changes in the EPPA model. Although the focus of this work is limited to electric heating and cooling technologies, it does represent a shift from traditional demand-side modeling techniques by taking advantage of a complementary general equilibrium model. Given the nature of the model and of the research carried out, there are certainly areas for improvements and opportunities for further work on demand-side modeling in EPPA.

To begin work, this thesis is specifically focused on the U.S. economy. As indicated in some studies cited, the opportunities for the proliferation of high-efficiency demand-side technologies are plentiful in both the developed and the developing world. It would certainly be interesting to understand the economics of such technologies in countries with a power sector fuel mix that is very different from the U.S. – candidate countries include France (with a high penetration of nuclear), Germany (with policies geared towards the growth of renewables) and developing countries like India and China.

Second, even within the U.S., the implications of these technologies could vary extensively. The efficiency of technologies certainly depends on climate conditions, and their acceptance depends on factors such as age group and income (Liao & Chang, 2002). It would be useful to test technology changes on specific regions and income groups. Such an approach could also appreciate the diversity in state policies on energy efficiency (American Council for an Energy-Efficient Economy, 2011).

Also, there are factors beyond costs that can influence the adoption of energy efficiency technologies. Significant work has been done on market failures associated with energy efficiency adoption – see (Gillingham, Newell, & Palmer, 2009) and (Fuller, Kunkel, Zimring, Hoffman, Soroye, & Goldman, 2010). The EPPA model may not be able to fully capture some non-economic factors of market adoption, including financing mechanisms and consumer behavior patterns and choices.

Finally, there are a variety of technologies that can influence energy use in the residential sector – not only is there a great diversity of technologies in the heating and cooling space, but technologies that focus on electrical appliances (TV's, computers, etc.) also deserve more attention given their growing role in residential energy consumption. Given that the current model setup represents an aggregate technology for new heating and cooling technologies, the next step in modeling demand-side technology changes in the EPPA model would be to split household energy consumption into each of the

areas of consumption i.e. space heating, space cooling, water heating and appliances and hence provide a greater level of technology detail. One may also consider utilizing the CGE framework of the EPPA model in conjunction with bottom-up demand side models that can focus more specifically on technology changes taking place in this space.

However, there are certain conclusions of this study that are critical in spite of the caveats identified above. Some of these overall results are summarized in the following paragraphs:

- **Household Specific Conclusions**

- Based on the results seen from the EPPA model, policies that support electrification have the potential to increase household electricity consumption by an amount in magnitude comparable to the decrease that might be seen by a carbon tax.
- Policies that incentivize electrification in households are also useful at reducing gas consumption since there is enough opportunity for fuel-switching from gas to electricity with the proliferation of high efficiency electric heating technologies.
- At the household level, the results indicate that a 25% subsidy on electricity prices reduces household emissions to a level of comparable with those seen from a high carbon price. This is due to a decrease in gas use at the households and the proliferation of high-efficiency electric appliances.

- **Economy-Wide Conclusions**

- Although residential electrification policies may reduce end-use household emissions, they do not reduce emissions at an economy-wide level. The fuel mix of the power sector influences overall emissions and hence any policy that supports greater electricity use in households needs to be thought of alongside the electricity fuel mix. The model results indicate that subsidizing electricity and advancing electric HVAC technologies actually increases economy-wide emissions. A variety of studies that look at the impact of electrification and energy efficiency in the residential sector on the economy do not explicitly clarify what they mean by energy efficiency. As mentioned, electrifying the

household sector will be most beneficial in reducing emissions if the power sector also moves towards lower carbon intensity. Hence, when evaluating the impact of electric technology changes in households or any other end-uses, it is critical to acknowledge the emissions associated with producing electricity along with the end-use efficiency.

Bibliography

Alberini, A., Gans, W., & Velez, D. (2010). *Residential Consumption of Gas and Electricity in the US: What are the Effects of Prices and Energy-Efficiency Investments?* College Park, MD: University of Maryland.

American Council for an Energy-Efficient Economy. (2011). *State Energy Efficiency Resource Standard (EERS) Activity*. Washington, DC.

American Council for an Energy-Efficient Economy. (2012). *The Efficiency Boom: Cashing In on the Savings from Appliance Standards*. Washington, D.C.: American Council for an Energy-Efficient Economy and Appliance Standards Awareness Project.

Babiker, M., Metcalf, G., & Reilly, J. (2003). Tax distortions and global climate policy. *Journal of Environmental Economics and Management*, 46, 269-287.

Chandler, J. (2010). A Preliminary Look at Electric Efficiency Potential. *The Electricity Journal*, 23 (1), 85-91.

Davis, L. (2008). Durable goods and residential demand for energy and water: evidence from a field trial. *Rand Journal of Economics*, 39 (2), 530-546.

Dubin, J., & McFadden, D. (1984). An Econometric Analysis of Residential Electric Appliance Holding and Consumption. *Econometrica*, 52 (2), 345-362.

Dubin, J., Miedema, A., & Chandran, R. (1986). Price effects of energy-efficient technologies: a study of residential demand for heating and cooling. *Rand Journal of Economics*, 17 (3).

EIA. (2011). *Annual Energy Review 2010*. United States Energy Information Administration (EIA).

EIA. (2012). *Residential Energy Consumption*. Retrieved Jan 2012, from U.S. Energy Information Administration: <http://www.eia.gov/consumption/residential/data/2009/>

EIA. (2005). *Residential Energy Consumption Survey: Energy Consumption and Expenditures Tables*. United States Energy Information Administration (EIA).

Fuller, M., Kunkel, C., Zimring, M., Hoffman, I., Soroye, K., & Goldman, C. (2010). *Driving Demand for Home Energy Improvements*. Environmental Energy Technologies Division, Lawrence Berkeley National Laboratory.

Gillingham, K., Newell, R., & Palmer, K. (2009). *Energy Efficiency Economics and Policy*. Washington, D.C.: Resources for the Future.

Goldstein, D., Martinez, S., & Roy, R. (2011). Are There Rebound Effects from Energy Efficiency? – An Analysis of Empirical Data, Internal Consistency, and Solutions. *Electricity Policy*.

Intergovernmental Panel on Climate Change. (2007). *Contribution of Working Group III to the Fourth Assessment Report of the Intergovernmental Panel on Climate Change: Summary for Policymakers*. Cambridge, United Kingdom, and New York, NY.: Cambridge University Press.

International Energy Agency. (2008). *Promoting Energy Efficiency Investments: Case Studies in the Residential Sector*. Paris: International Energy Agency.

Jacoby, H., & Ellerman, A. (2004). The safety valve and climate policy. *Energy Policy* , 32(4), 481-491.

Jacoby, H., Reilly, J., McFarland, J., & Paltsev, S. (2006). Technology and technical change in the MIT EPPA model. *Energy Economics* , 28, 610-631.

Kutscher, C. (2007). *Tackling Climate Change in the U.S.: Potential Carbon Emissions*. American Solar Energy Society.

Lawrence Livermore National Laboratory. (2011). *Energy Flow Annotated*.

Liao, H.-C., & Chang, T.-F. (2002). Space-heating and water-heating energy demands of the aged in the US. *Energy Economics* , 24, 267-284.

Mathiesen, L. (1985). Computation of economic equilibrium by a sequence of linear complementarity problems. *Mathematical Programming Study* , 23, 144-162.

McKinsey Global Energy and Materials. (2009). *Unlocking Energy Efficiency in the U.S. Economy: Executive Summary*. McKinsey & Company.

Moniz, Ernest et al. (2011). *The Future of Natural Gas: An Interdisciplinary MIT Study*. Cambridge.

Paltsev, S., Viguier, L., Babiker, M., Reilly, J., & Tay, K. (2004). *Disaggregating Household Transport in the MIT-EPPA Model*. Cambridge, MA: MIT Joint Program on the Science and Policy of Global Change.

Paltsev, Sergey et al. (2005). *The MIT Emissions Prediction and Policy Analysis (EPPA) Model:Version 4*. Cambridge, MA: MIT Joint Program on the Science and Policy of Global Change.

Rutherford, T. (1995). *Demand Theory and General Equilibrium: An Intermediate Level Introduction to MPSGE*.